

WE CARE FOR YOUR NEEDS.

AXIAL FAN

AXF Series



TABLE OF CONTENTS

CONSTRUCTION FEATURES	03-04
DIMENSIONS	05
FAN DATA	06-35
ACCESSORIES	36
SYSTEM EFFECT.....	37

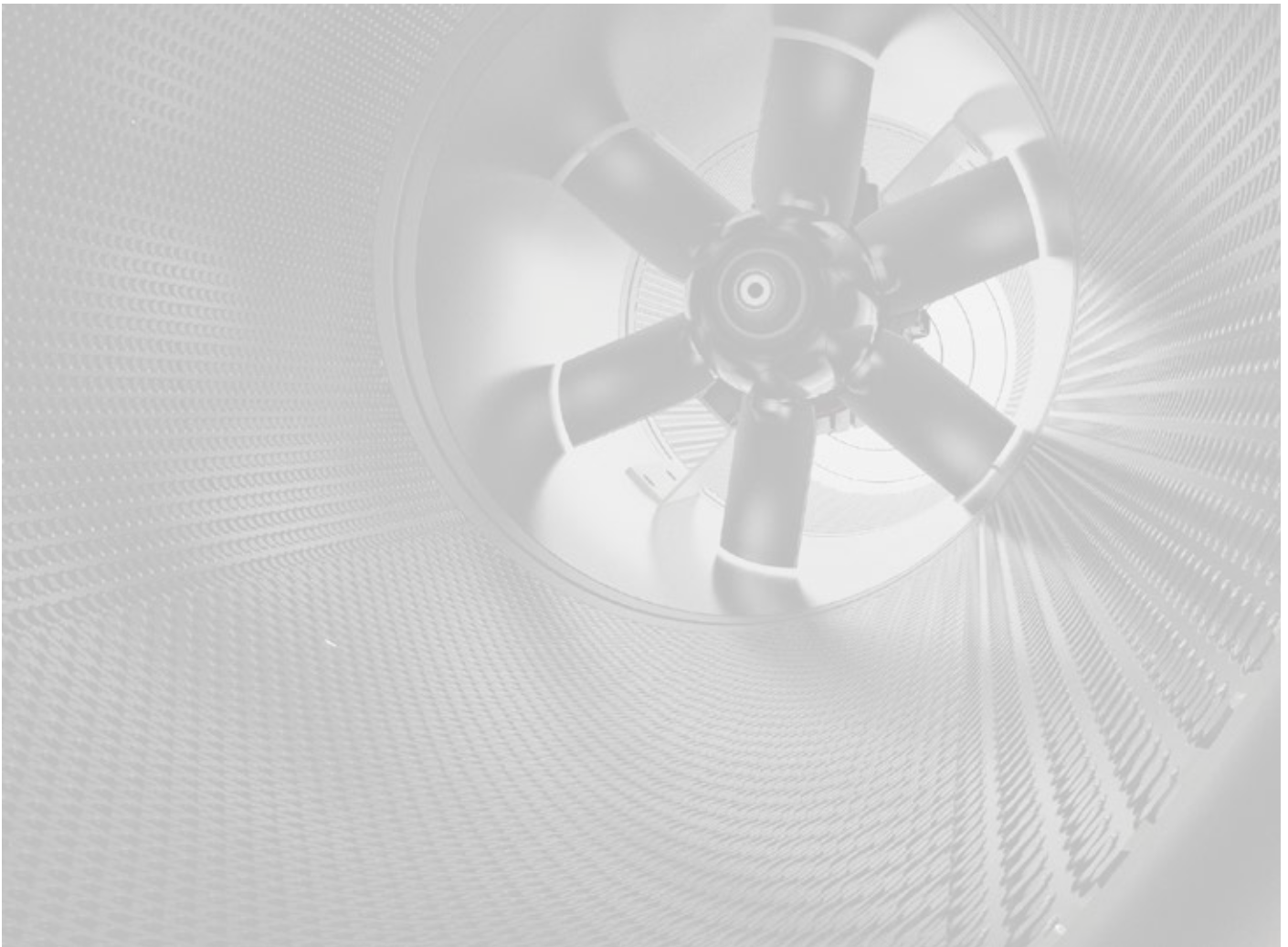

CONSTRUCTION FEATURES

AXIAL FAN

ORDER CODE

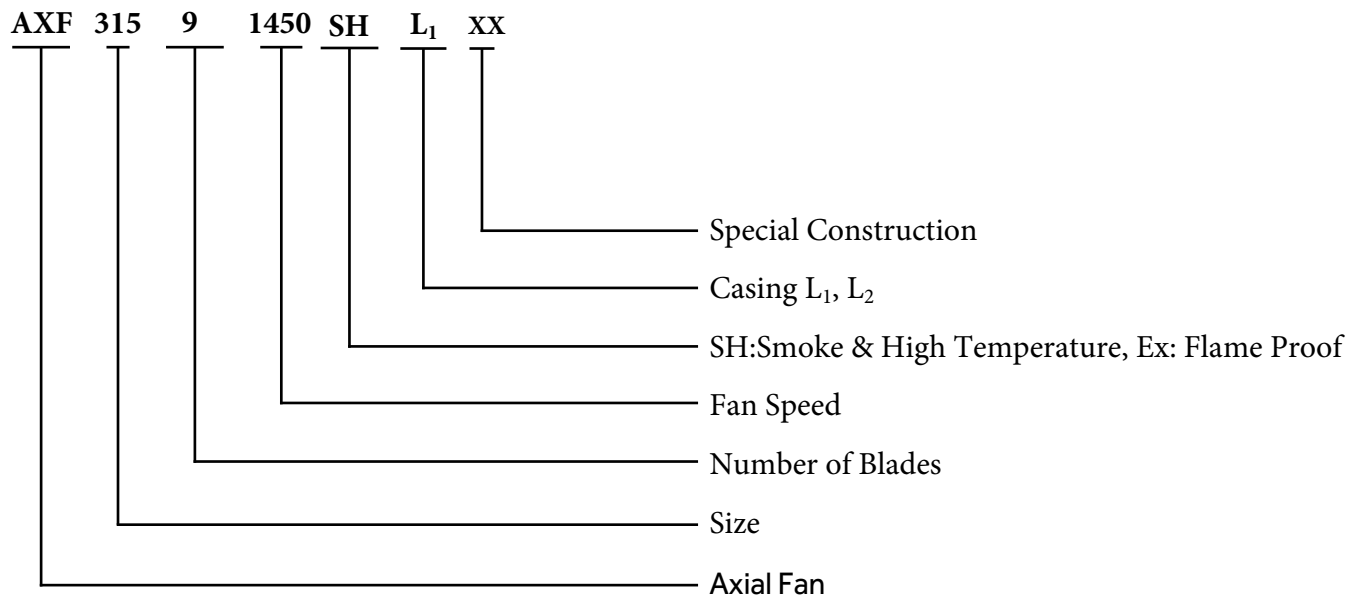

CONSTRUCTION

ETC Axial flow fans are specially manufactured for all applications and mounting positions in case sizes from 315 to 1600 mm diameter. The performance range is from 1000 m³/h up to 230000 m³/h air volume and total pressure up to 1500 Pa. Please consult factory in case of special applications such as: explosion-proof, corrosion resistance, etc.

CASINGS

Fan casing and motor brackets are made of mild steel. All steel parts are hot dip galvanised after manufacturing. Flanges on both ends are drilled in accordance to DIN 24154,R2.

IMPELLERS

Impellers hubs and blades are made of cast aluminium alloy are balanced according to the *NFE 90-600* norms, quality G=6,3. The aerodynamical profile guarantees high efficiency and low noise the pitch adjustable blades allow correct duty point setting.

CERTIFICATIONS

Applus F400 Deg. C 120 Min., CE (IEC60335) EMC & RoHS



Energy Twin City certifies that the models AXF tested and passed for **F400 Deg. C for 120 Min.** The certified model fan carries the Applus label for fire safety certification.

Low Voltage Directive



IEC 60335-2-80:2015 in conjunction with IEC 60335-1:2010, COR1:2010, COR2:2011, AMD1:2013, AMD2:2016.

EMC Directive

EN 55014-1: 2017+A11: 2020; EN IEC 61000-3-2: 2019; EN 61000-3-3: 2013 +A1:2019; EN 55014-2: 2015(IEC 61000-4-2; IEC 61000-4-4; IEC 61000-4-5; IEC 61000-4-6; IEC 61000-4-11).



RoHS Directive

Restriction of Hazardous substances in Electrical and Electronic Equipments.

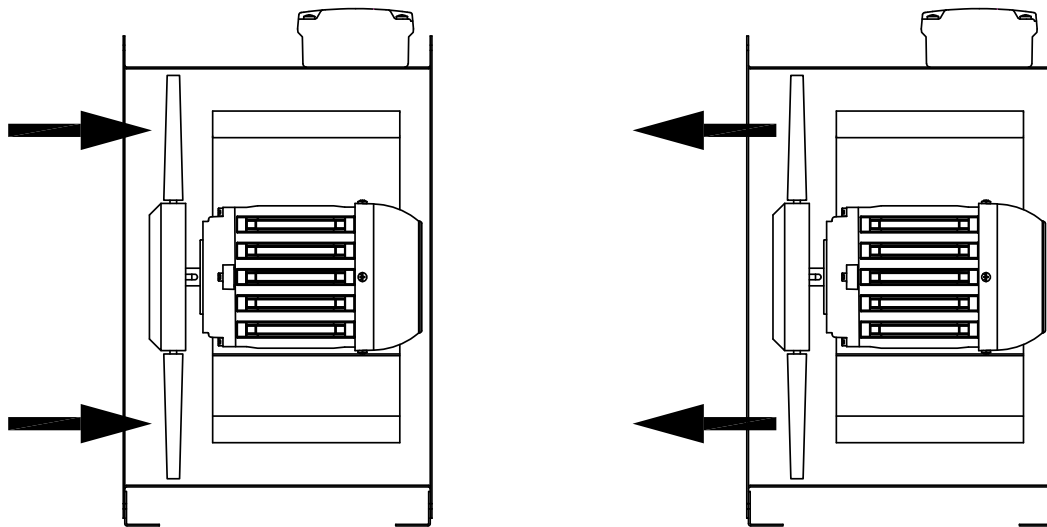

Fig-01

MOTORS

ETC use squirrel cage motors as per IEC 34. The standard motor have Class F insulation and IP 55 enclosure with continuous operating range from -40 C to +40 C. Motors for Smoke spill operation are rated for 400 degree C. for two hours.

FORMS OF RUNNINGS

AXF axial flow fans are available for all forms of running as per Fig- 01. When ordering, please indicate the form of running. Standard form of running is motor impeller direction. One label on the fan casing indicates the direction of the air flow and the rotation of the impeller.

FAN PERFORMANCE CURVES

The performance curves have been established in mounting position ducted inlet and ducted outlet and show the static pressure increase P_s as a function of the volume flow. The dynamic pressure P_d refers to the flange cross section at the outlet side of the fan. The impellers are tested according to the reduced tunnel method, norm *NFX 10-200*.

SOUND LEVELS

The ascertaining of the sound level follows the reverberant room method. The sound levels are measured according to the NFS 31-021 norms.

*Energy Twin city reserves the right to change the design, technical specification and dimensions without prior notice.

Ordering the Fan

When ordering please specify the below.

- Fan type and running form
- Fan code and type:
- Quantity required
- Duty required at standard air temperature , air volume in m^3/h at static pressure in Pa.
- Motor power rating in KW
- Electrical supply
- Accessories required

DIMENSIONAL DATA

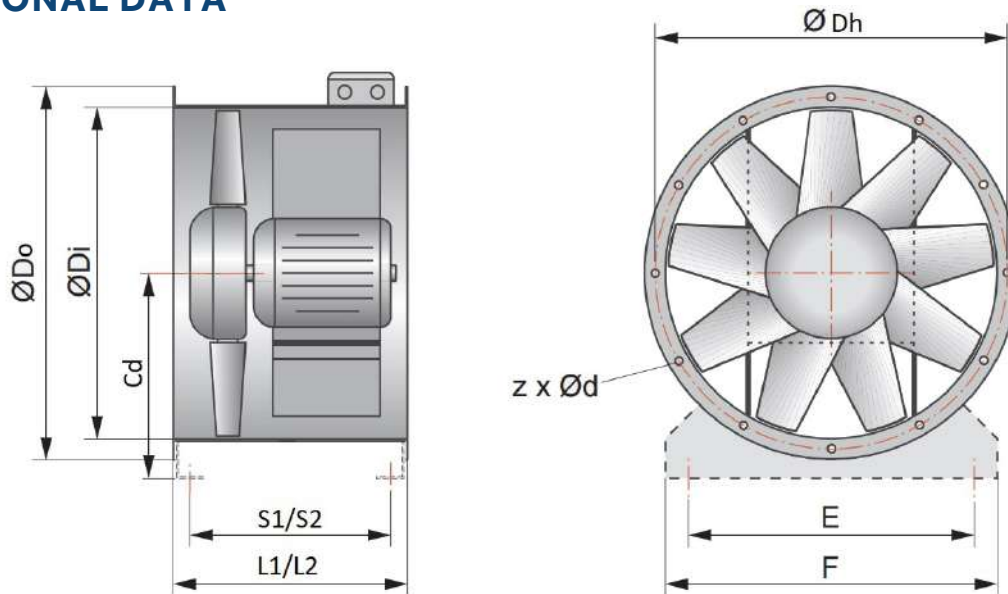

All dimensions are in mm

Size	ØDi	ØDo	ØDh	cd	E	F	L1	S1	z-Ød
315	320	398	366	205	265	315	420	358	8-Ø12
355	359	438	405	225	305	355	420	358	8-Ø12
400	401	484	448	250	350	400	435	373	12-Ø12
450	450	534	497	280	400	450	435	373	12-Ø12
500	503	584	551	315	440	500	470	398	12-Ø12

Size	ØDi	ØDo	ØDh	cd	E	F	L1	S1	z-Ød
							L2	S2	
560	560	664	629	345	500	560	470	398	16-Ø14
							700	626	
630	633	734	698	400	570	630	470	398	16-Ø14
							700	626	
710	710	814	775	450	650	710	470	396	16-Ø14
							700	626	
800	796	904	861	500	730	800	470	386	16-Ø14
							700	616	
900	894	1004	958	580	830	900	565	481	16-Ø14
							700	616	
1000	999	1105	1067	630	939	990	565	479	24-Ø14
							780	696	
1120	1125	1245	1200	690	1050	1110	700	594	24-Ø18
							1000	894	
1250	1250	1370	1337	750	1180	1240	700	594	24-Ø18
							1000	894	

Size	ØDi	ØDo	ØDh	cd	E	F	L2	S1	z-Ød
1400	1400	1525	1480	850	1330	1390	1000	892	32-Ø18
1600	1595	1725	1680	930	1530	1590	1000	892	32-Ø18

AXF 315-9/50Hz

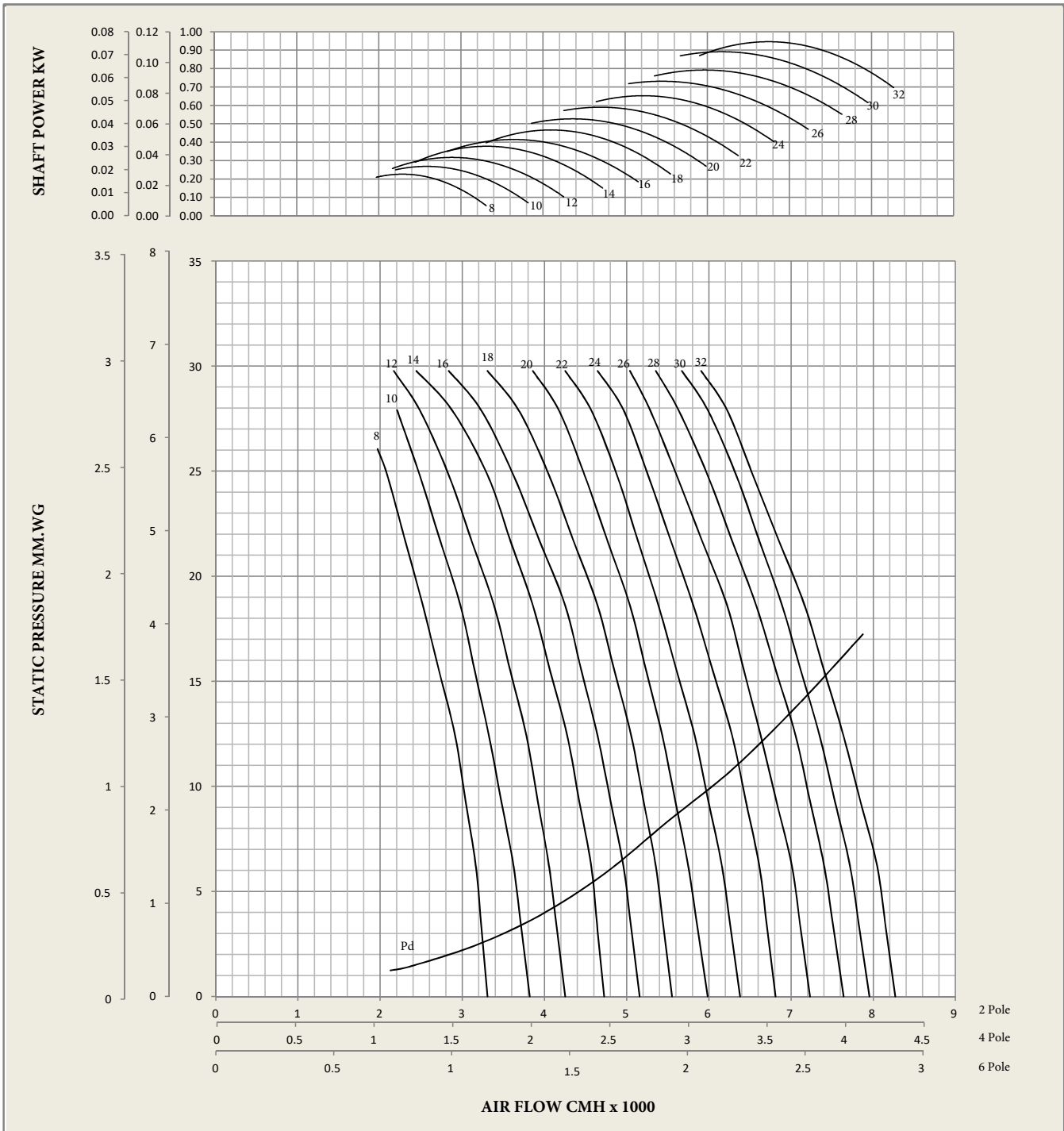

Sound Data (dBA)

Octave Bands	@ 20 Degree									@ 32 Degree								
	1	2	3	4	5	6	7	8	LWA	1	2	3	4	5	6	7	8	LWA
6 Pole	21	37	41	44	45	44	41	32	51	28	44	48	51	52	51	48	39	58
4 Pole	29	37	57	52	53	53	49	40	61	37	45	64	60	61	60	57	48	68
2 Pole	45	53	65	76	69	68	65	56	78	52	60	72	83	76	76	72	63	85

Motor Power (kW)

RPM	KW Max. L1	Frame Size Max. L1
6 Pole - 950	0.37	90
4 Pole - 1450	0.55	90
2 Pole - 2850	1.10	90

Fan Performance is in accordance to **ISO 5801** (Fans - Performance testing using standardized airways). The impellers are tested according to the reduced tunnel method norm NFX 10-200. The sound levels are measured according to the NFS 31-021 norms.

AXF 355-9/50Hz

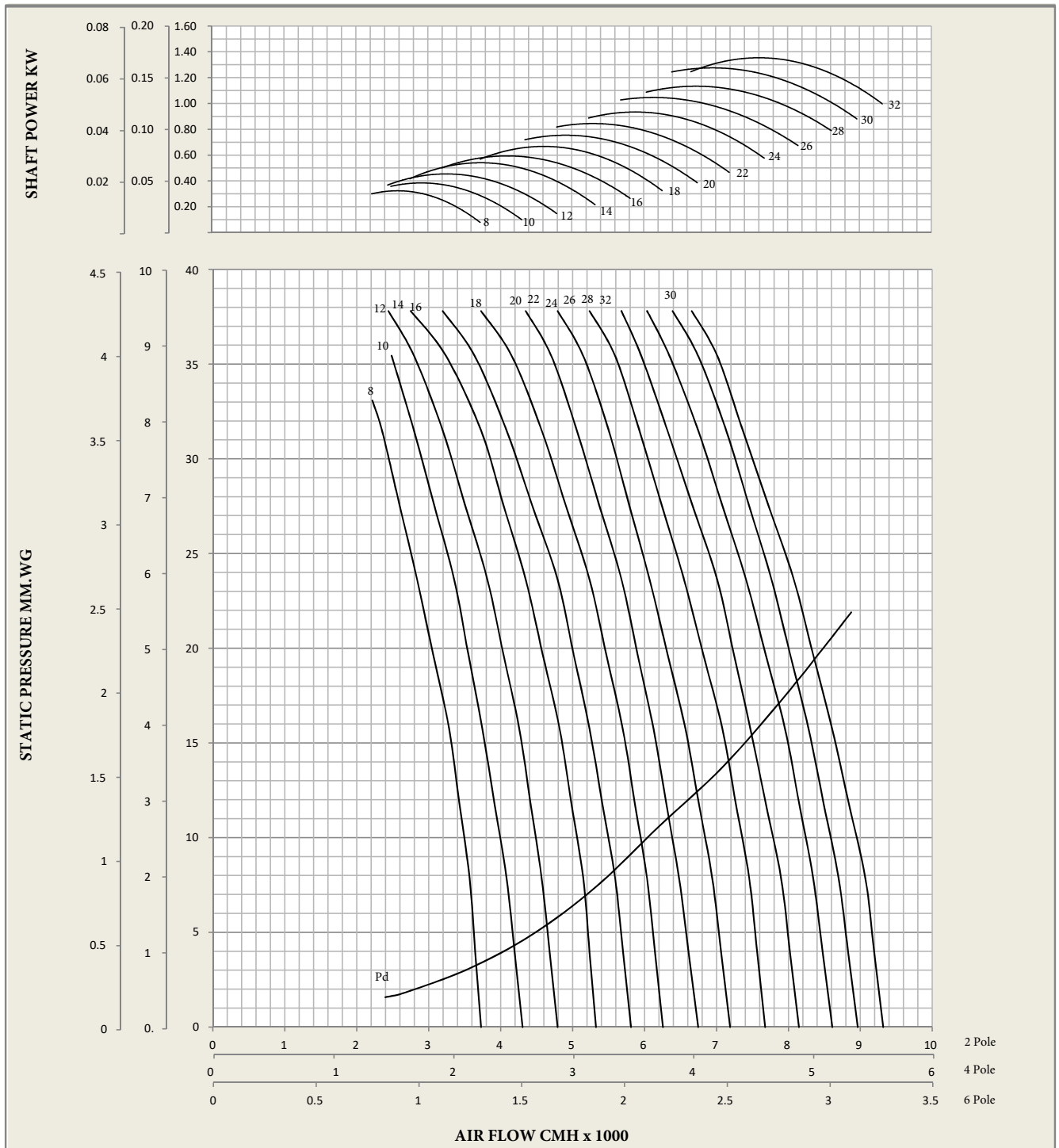

Sound Data (dBA)

Octave Bands	@ 20 Degree									@ 32 Degree								
	1	2	3	4	5	6	7	8	LWA	1	2	3	4	5	6	7	8	LWA
6 Pole	24	40	43	47	48	47	44	35	53	31	47	50	54	55	54	51	42	60
4 Pole	32	40	59	55	56	55	52	43	63	39	47	67	62	63	63	59	50	71
2 Pole	48	56	67	79	72	71	68	59	81	55	63	74	86	79	78	75	66	88

Motor Power (kW)

RPM	KW Max. L1	Frame Size Max. L1
6 Pole - 950	0.37	100
4 Pole - 1450	0.55	100
2 Pole - 2850	2.20	100

Fan Performance is in accordance to **ISO 5801** (Fans - Performance testing using standardized airways). The impellers are tested according to the reduced tunnel method norm NFX 10-200. The sound levels are measured according to the NFS 31-021 norms.

AXF 400-9/50Hz

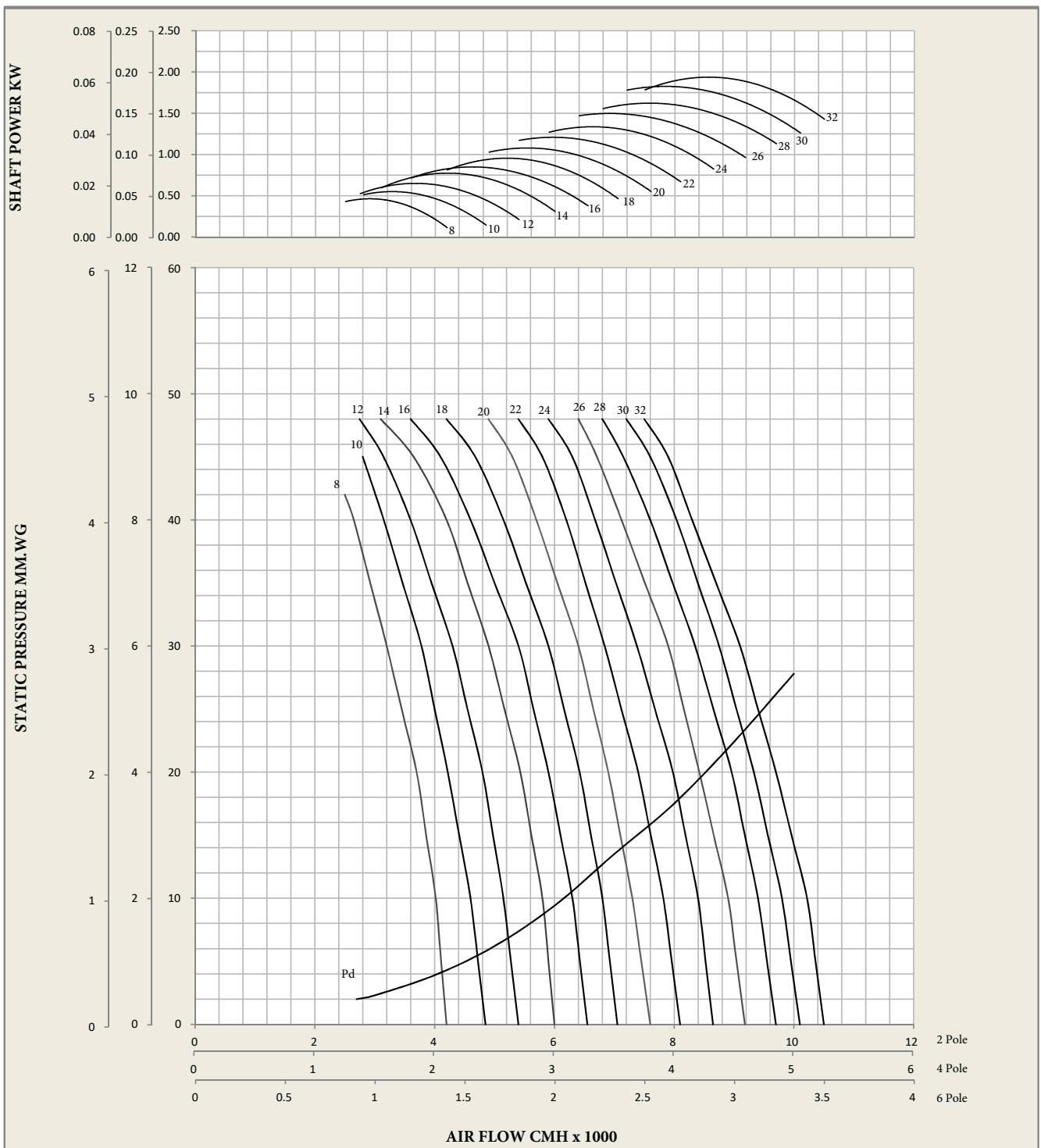

Sound Data (dBA)

Octave Bands	@ 20 Degree									@ 32 Degree								
	1	2	3	4	5	6	7	8	LWA	1	2	3	4	5	6	7	8	LWA
6 Pole	26	42	46	49	50	50	46	37	56	33	49	53	56	57	57	53	44	63
4 Pole	34	42	62	57	59	58	55	45	66	42	50	69	65	66	65	62	53	73
2 Pole	50	58	70	81	74	74	70	61	83	57	65	77	88	82	81	78	68	90

Motor Power (kW)

RPM	KW Max. L1	Frame Size Max. L1
6 Pole - 950	0.55	100
4 Pole - 1450	1.10	100
2 Pole - 2850	3.00	100

Fan Performance is in accordance to **ISO 5801** (Fans - Performance testing using standardized airways). The impellers are tested according to the reduced tunnel method norm NFX 10-200. The sound levels are measured according to the NFS 31-021 norms.

AXF 450-9/50Hz

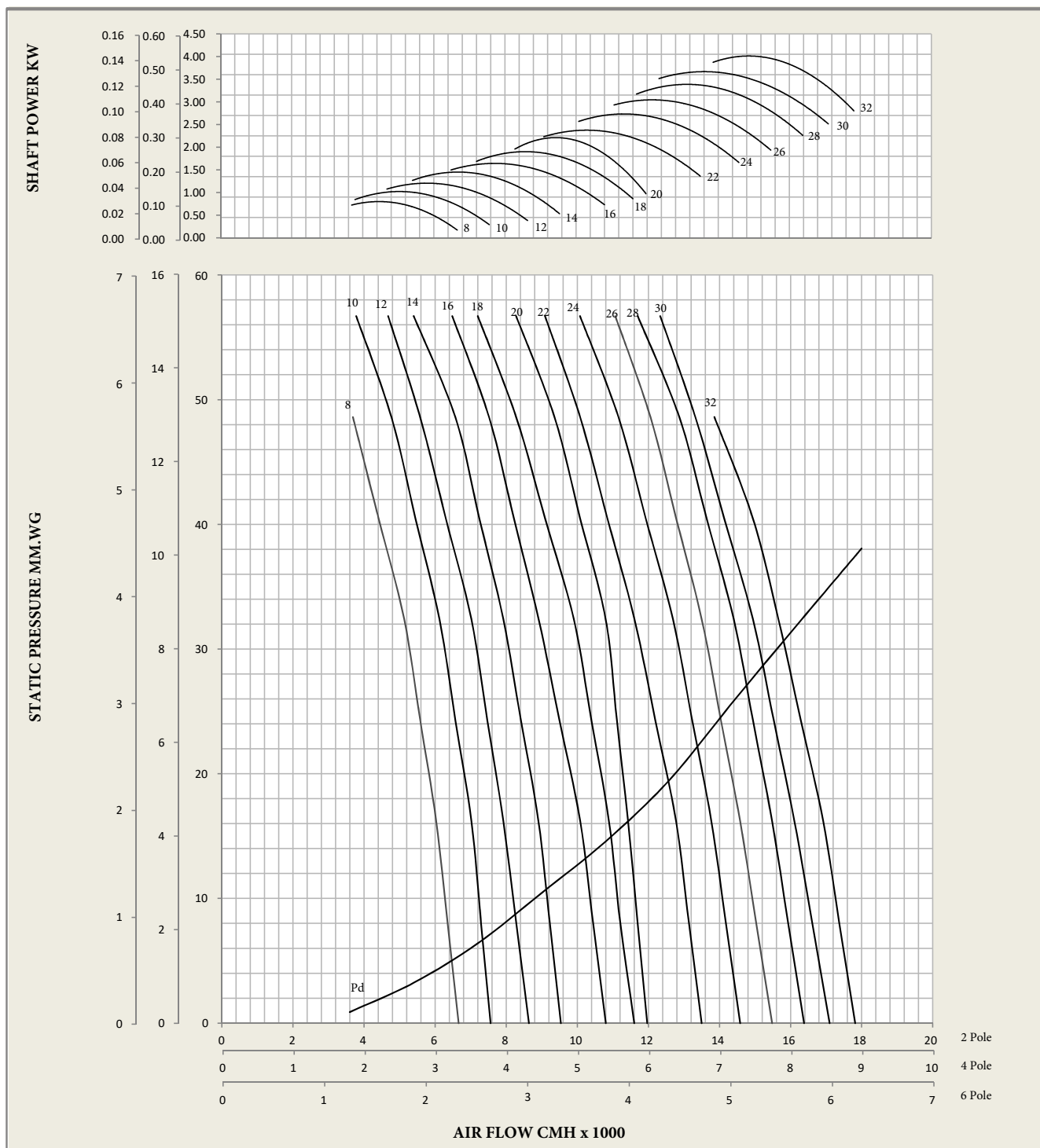

Sound Data (dBA)

Octave Bands	@ 20 Degree									@ 32 Degree								
	1	2	3	4	5	6	7	8	LWA	1	2	3	4	5	6	7	8	LWA
6 Pole	30	46	50	53	55	54	51	41	60	38	54	57	61	62	61	58	49	67
4 Pole	39	47	67	62	63	62	59	50	70	46	54	73	69	70	69	66	57	77
2 Pole	53	61	73	84	77	77	73	64	86	61	69	81	92	86	85	82	72	94

Motor Power (kW)

RPM	KW Max. L1	Frame Size Max. L1
6 Pole - 950	0.75	112
4 Pole - 1450	1.50	112
2 Pole - 2850	4.00	112

Fan Performance is in accordance to **ISO 5801** (Fans - Performance testing using standardized airways).The impellers are tested according to the reduced tunnel method norm NFX 10-200.The sound levels are measured according to the NFS 31-021 norms.

AXF 500-9/50Hz

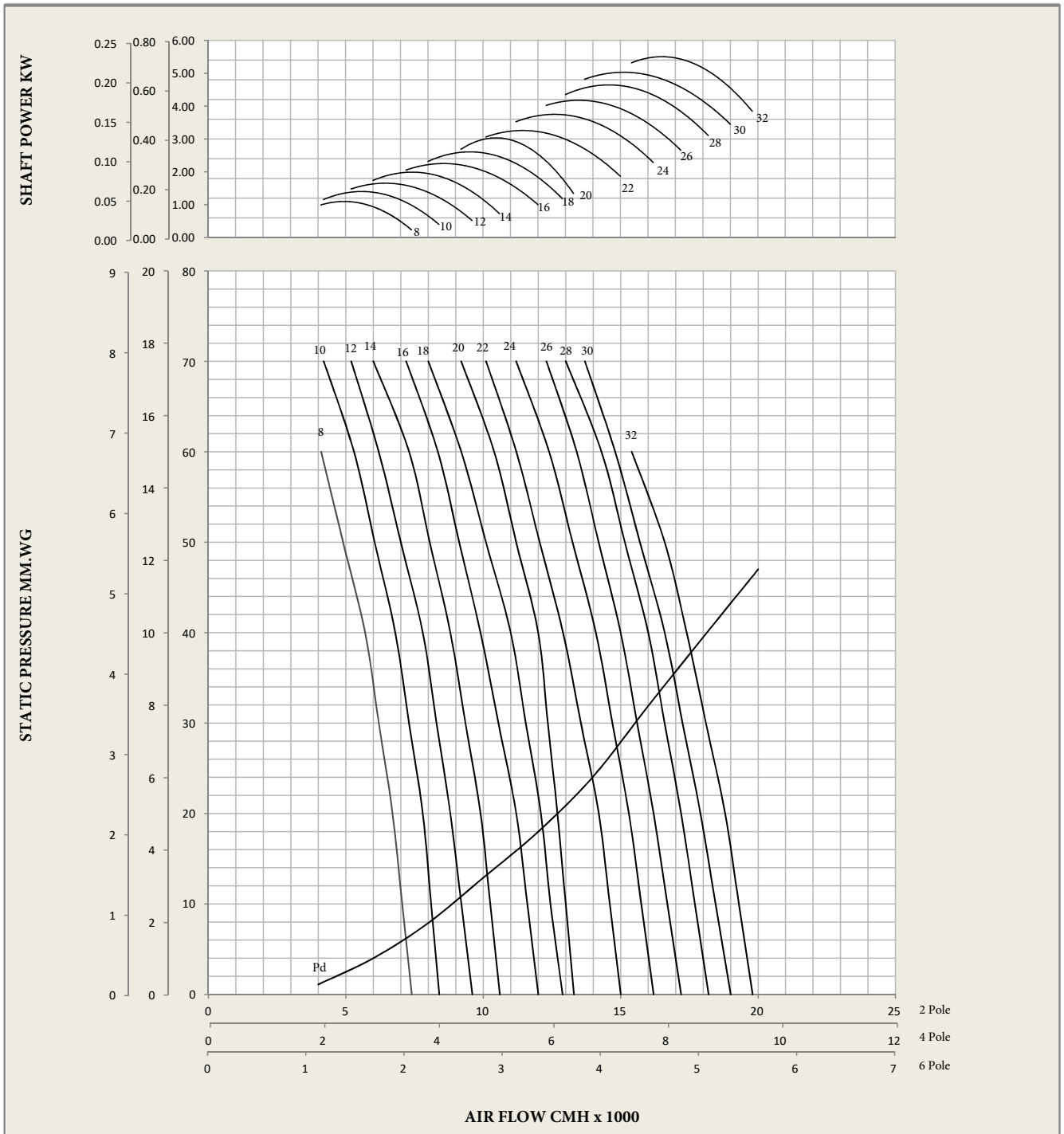

Sound Data (dBA)

Octave Bands	@ 20 Degree									@ 32 Degree								
	1	2	3	4	5	6	7	8	LWA	1	2	3	4	5	6	7	8	LWA
6 Pole	33	49	52	56	57	56	53	44	62	40	56	60	63	64	63	60	51	70
4 Pole	41	49	69	64	65	65	61	52	73	48	56	76	71	72	72	68	59	80
2 Pole	55	64	75	86	80	79	76	67	88	52	72	83	95	88	87	84	75	97

Motor Power (kW)

RPM	KW Max. L1	Frame Size Max. L1
6 Pole - 950	1.10	132
4 Pole - 1450	3.00	132
2 Pole - 2850	7.50	132

Fan Performance is in accordance to **ISO 5801** (Fans - Performance testing using standardized airways).The impellers are tested according to the reduced tunnel method norm NFX 10-200.The sound levels are measured according to the NFS 31-021 norms.

AXF 560-9/50Hz

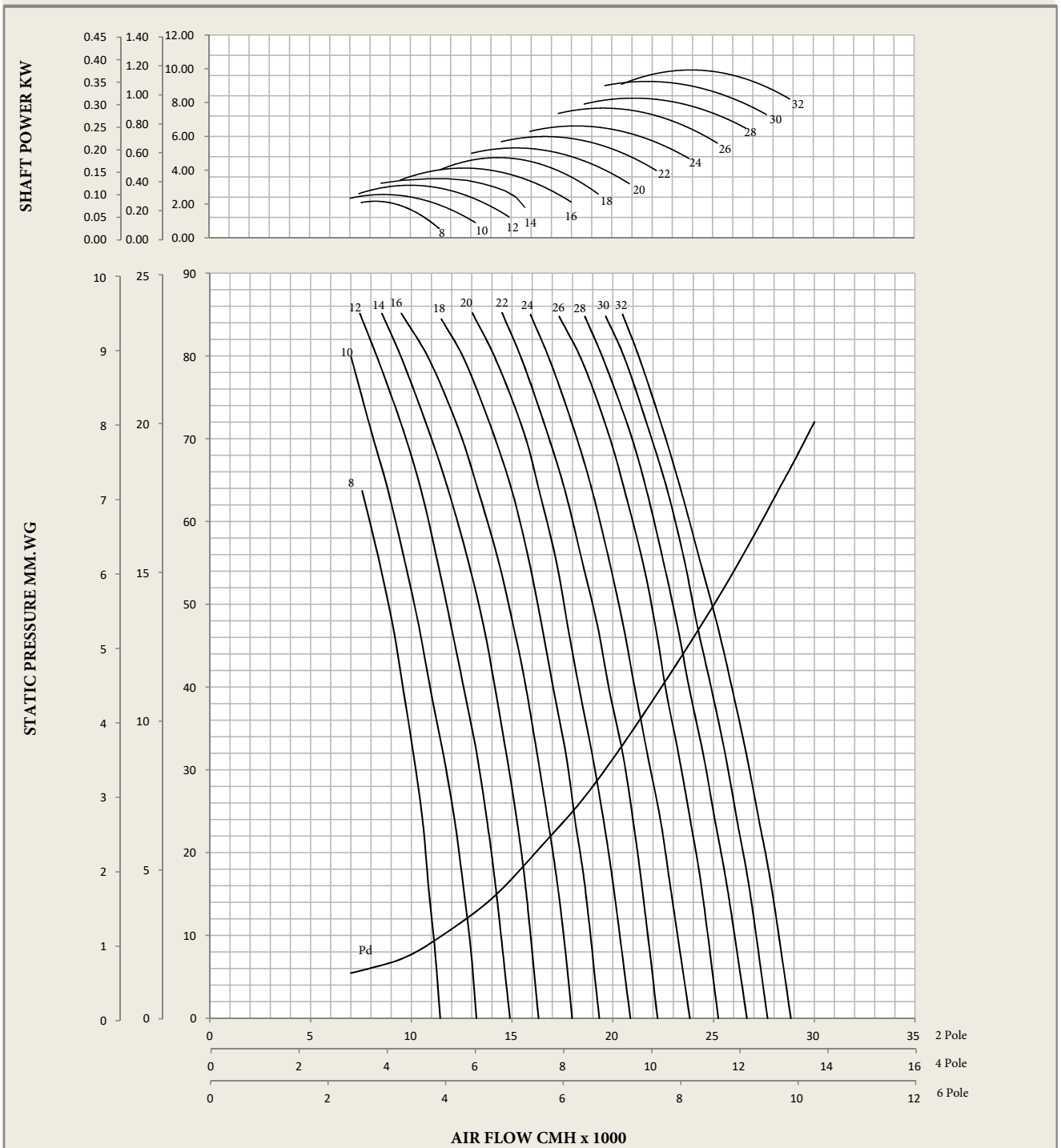

Sound Data (dBA)

Octave Bands	@ 20 Degree									@ 32 Degree								
	1	2	3	4	5	6	7	8	LWA	1	2	3	4	5	6	7	8	LWA
6 Pole	37	53	57	60	61	61	57	48	67	45	61	65	68	69	68	65	56	75
4 Pole	46	54	74	69	70	69	66	57	77	54	62	81	77	78	77	74	65	85
2 Pole	61	69	81	92	86	85	82	72	94	68	77	88	99	93	92	89	80	101

Motor Power (kW)

RPM	KW Max. L1/L2	Frame Size Max. L1/L2
6 Pole - 950	1.10/5.50	112/132
4 Pole - 1450	4.00/7.50	112/132
2 Pole - 2850	4.00/9.20	112/132

Fan Performance is in accordance to **ISO 5801** (Fans - Performance testing using standardized airways). The impellers are tested according to the reduced tunnel method norm NFX 10-200. The sound levels are measured according to the NFS 31-021 norms.

AXF 630-9/50Hz

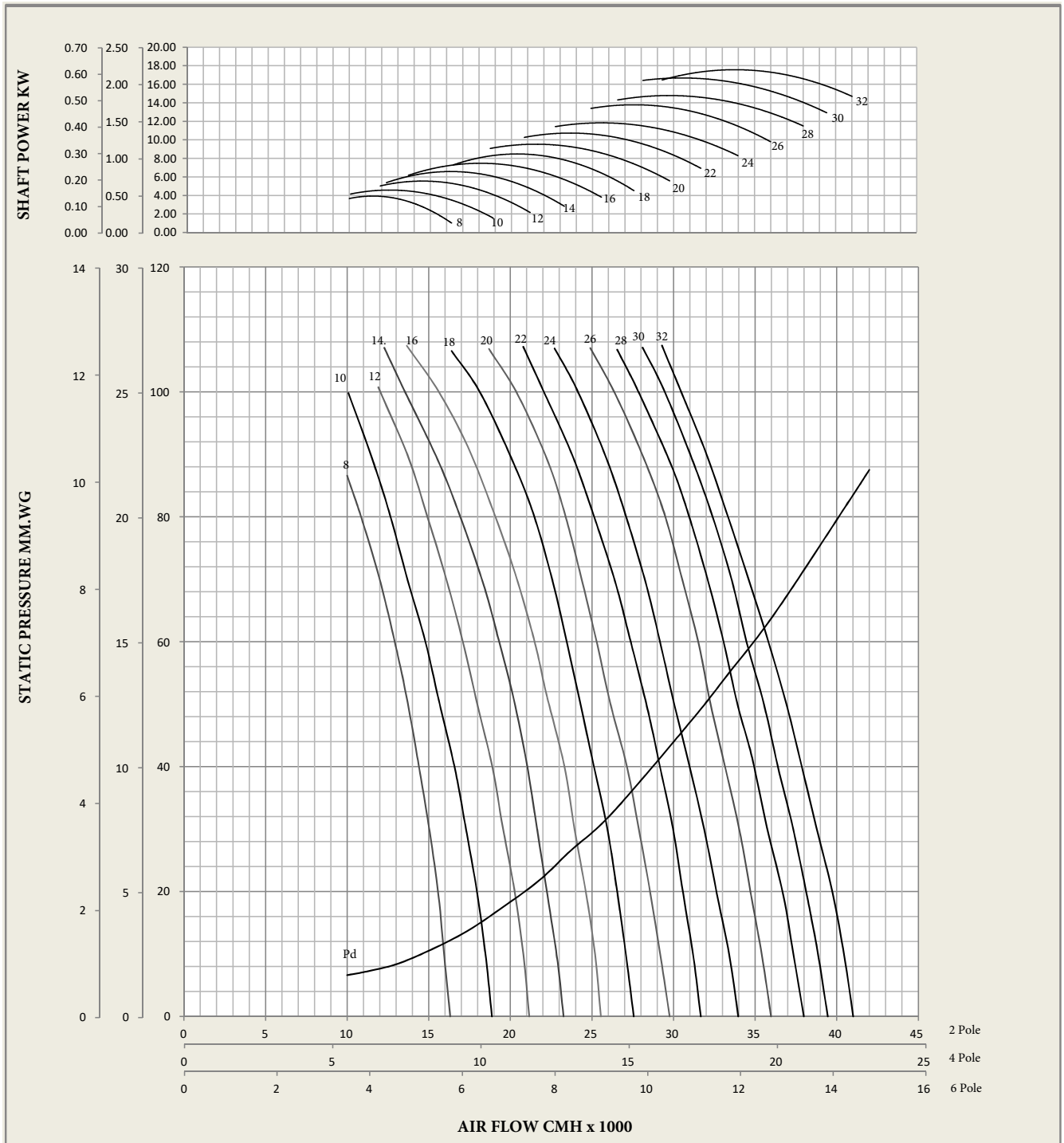

Sound Data (dBA)

Octave Bands	@ 20 Degree									@ 32 Degree								
	1	2	3	4	5	6	7	8	LWA	1	2	3	4	5	6	7	8	LWA
6 Pole	41	57	60	64	65	64	61	52	70	48	67	68	71	72	72	68	59	78
4 Pole	49	58	77	72	74	73	70	61	81	57	65	85	80	81	81	77	68	89
2 Pole	65	73	84	96	89	88	85	76	98	72	80	92	103	96	95	92	83	105

Motor Power (kW)

RPM	KW Max. L1/L2	Frame Size Max. L1/L2
6 Pole - 950	2.20/5.50	112/132
4 Pole - 1450	4.00/7.50	112/132
2 Pole - 2850	4.00/9.2	112/132

Fan Performance is in accordance to **ISO 5801** (Fans - Performance testing using standardized airways). The impellers are tested according to the reduced tunnel method norm NFX 10-200. The sound levels are measured according to the NFS 31-021 norms.

AXF 710-6/50Hz

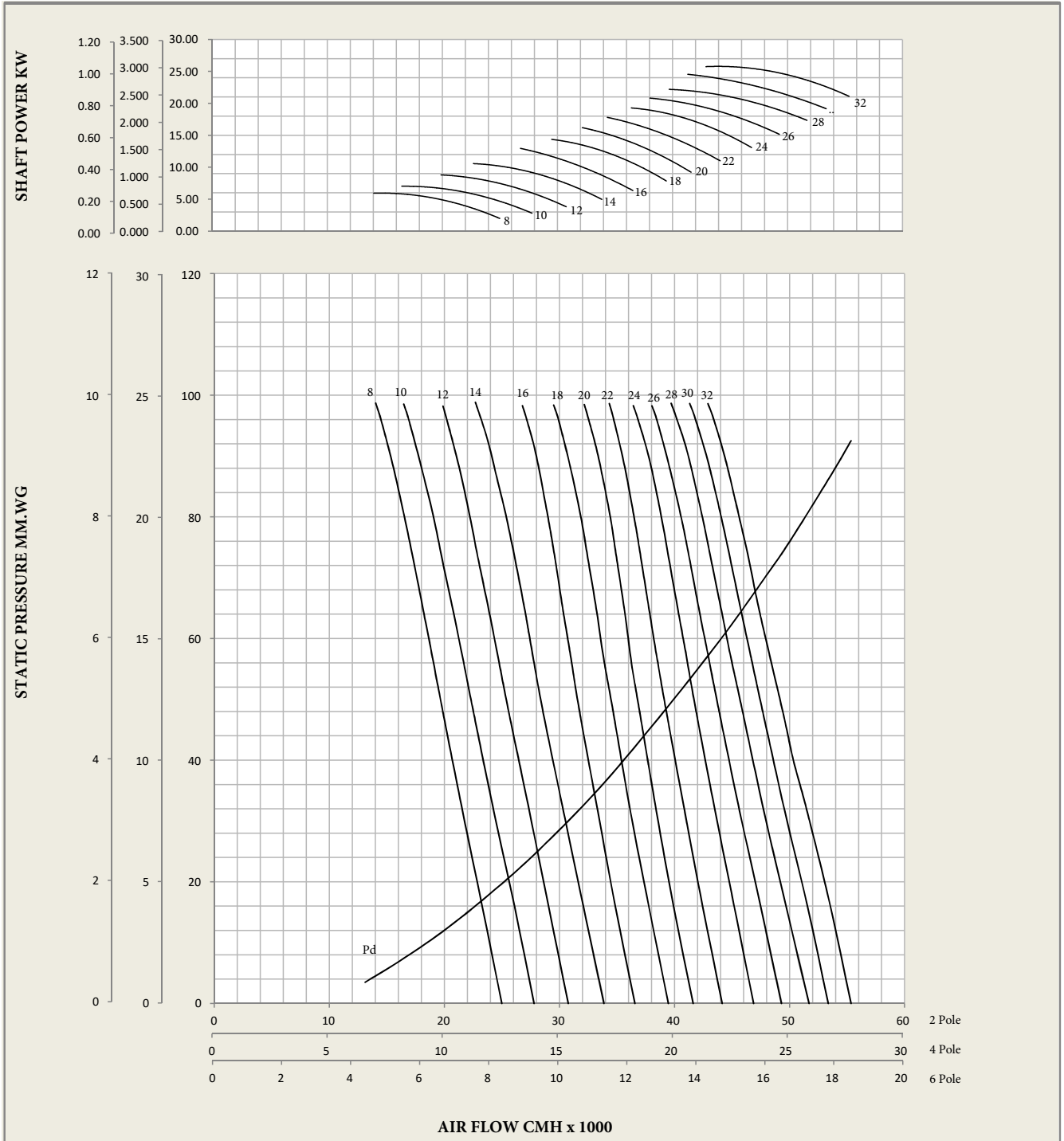

Sound Data (dBA)

Octave Bands	@ 20 Degree									@ 32 Degree								
	1	2	3	4	5	6	7	8	LWA	1	2	3	4	5	6	7	8	LWA
6 Pole	44	60	64	67	69	68	65	55	74	50	66	70	73	75	74	71	61	80
4 Pole	53	69	73	76	77	77	73	64	83	59	75	79	82	83	83	79	70	89
2 Pole	68	76	96	91	92	92	88	79	100									

Motor Power (kW)

RPM	KW Max. L1/L2	Frame Size Max. L1/L2
6 Pole - 950	2.20/5.50	112/132
4 Pole - 1450	4.00/7.50	112/132
2 Pole - 2850	4.00/9.20	112/132

Fan Performance is in accordance to **ISO 5801** (Fans - Performance testing using standardized airways).The impellers are tested according to the reduced tunnel method norm NFX 10-200.The sound levels are measured according to the NFS 31-021 norms.

AXF 710-9/50Hz

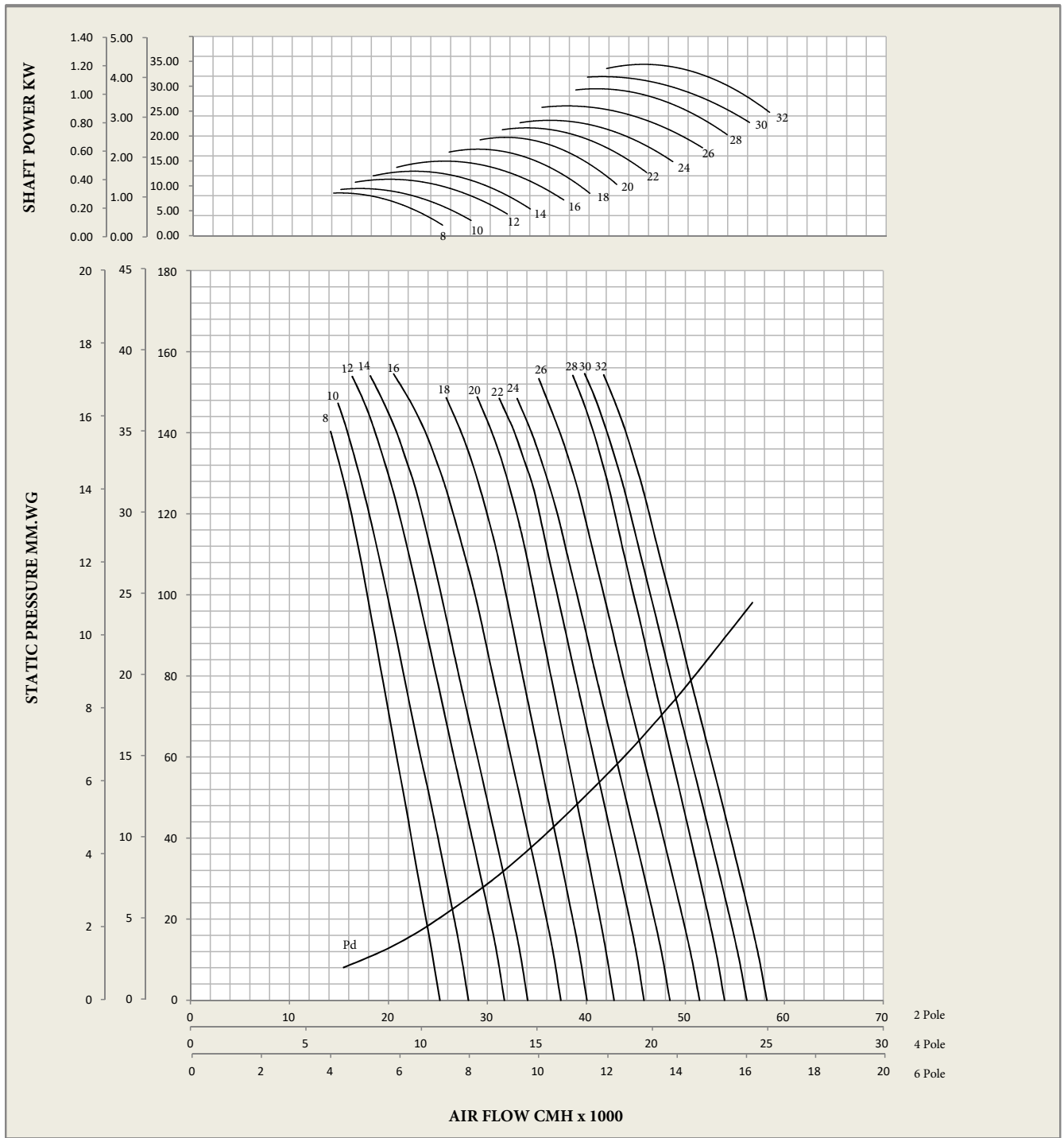

Sound Data (dBA)

Octave Bands	@ 20 Degree									@ 32 Degree								
	1	2	3	4	5	6	7	8	LWA	1	2	3	4	5	6	7	8	LWA
6 Pole	45	61	65	68	69	69	65	56	75	51	67	71	74	76	75	72	62	81
4 Pole	55	62	81	77	78	77	74	65	85	60	68	88	83	84	84	80	71	92
2 Pole	69	77	89	100	93	92	89	80	102									

Motor Power (kW)

RPM	KW Max. L1/L2	Frame Size Max. L1/L2
6 Pole - 950	2.20/5.50	112/132
4 Pole - 1450	4.00/7.50	112/132
2 Pole - 2850	4.00/9.20	112/132

Fan Performance is in accordance to **ISO 5801** (Fans - Performance testing using standardized airways). The impellers are tested according to the reduced tunnel method norm NFX 10-200. The sound levels are measured according to the NFS 31-021 norms.

AXF 800-3/50Hz

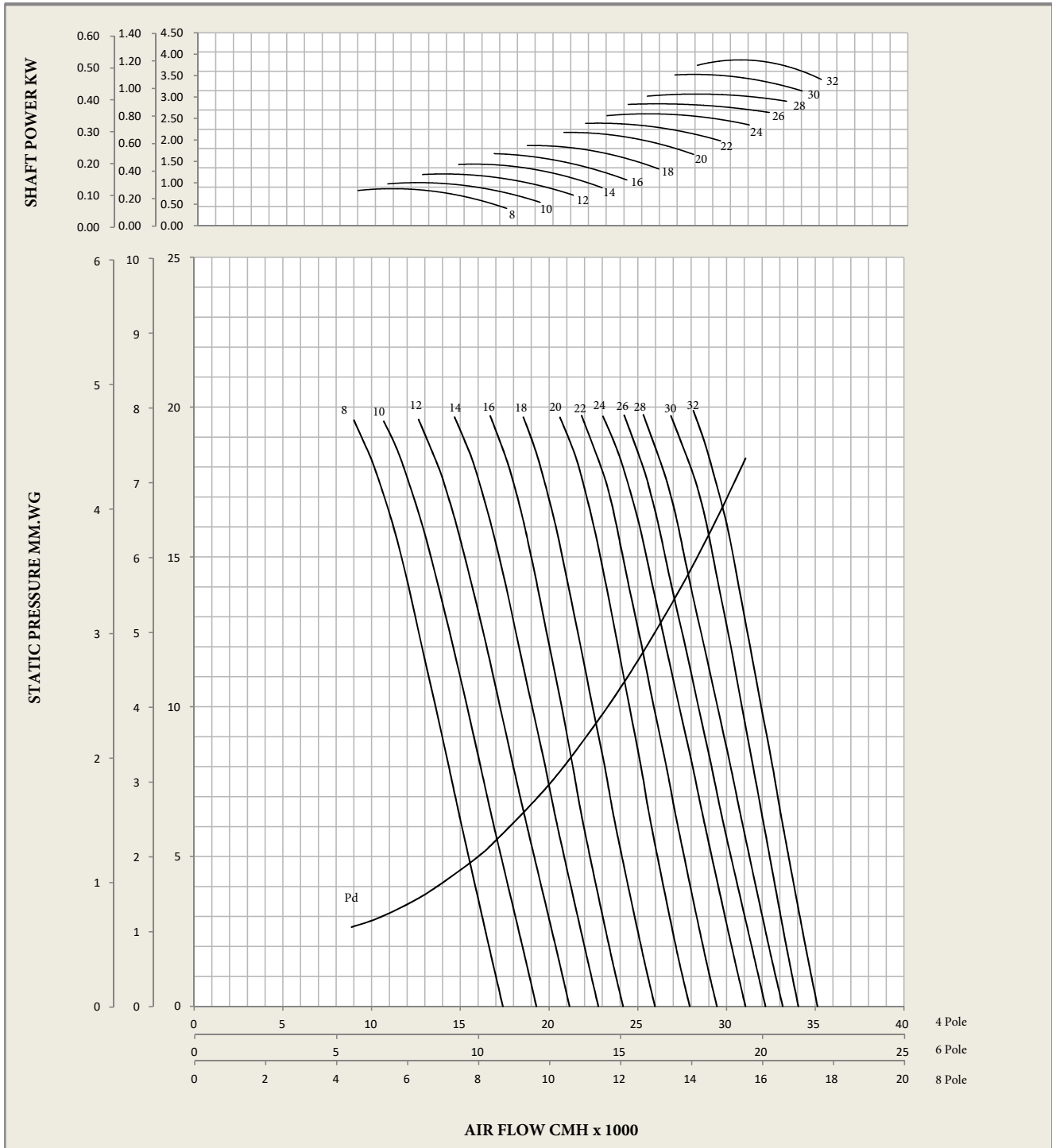

Sound Data (dBA)

Octave Bands	@ 20 Degree									@ 32 Degree								
	1	2	3	4	5	6	7	8	LWA	1	2	3	4	5	6	7	8	LWA
6 Pole	54	55	66	69	71	70	67	58	76	60	60	71	75	76	75	72	63	81
4 Pole	63	63	75	78	79	79	75	66	85	68	69	80	83	85	84	81	72	90

Motor Power (kW)

RPM	KW Max. L1/L2	Frame Size Max. L1/L2
8 Pole - 750	1.50/7.50	112/160
6 Pole - 950	2.20/11.0	112/160
4 Pole - 1450	4.00/15.0	112/160

Fan Performance is in accordance to **ISO 5801** (Fans - Performance testing using standardized airways). The impellers are tested according to the reduced tunnel method norm NFX 10-200. The sound levels are measured according to the NFS 31-021 norms.

AXF 800-6/50Hz

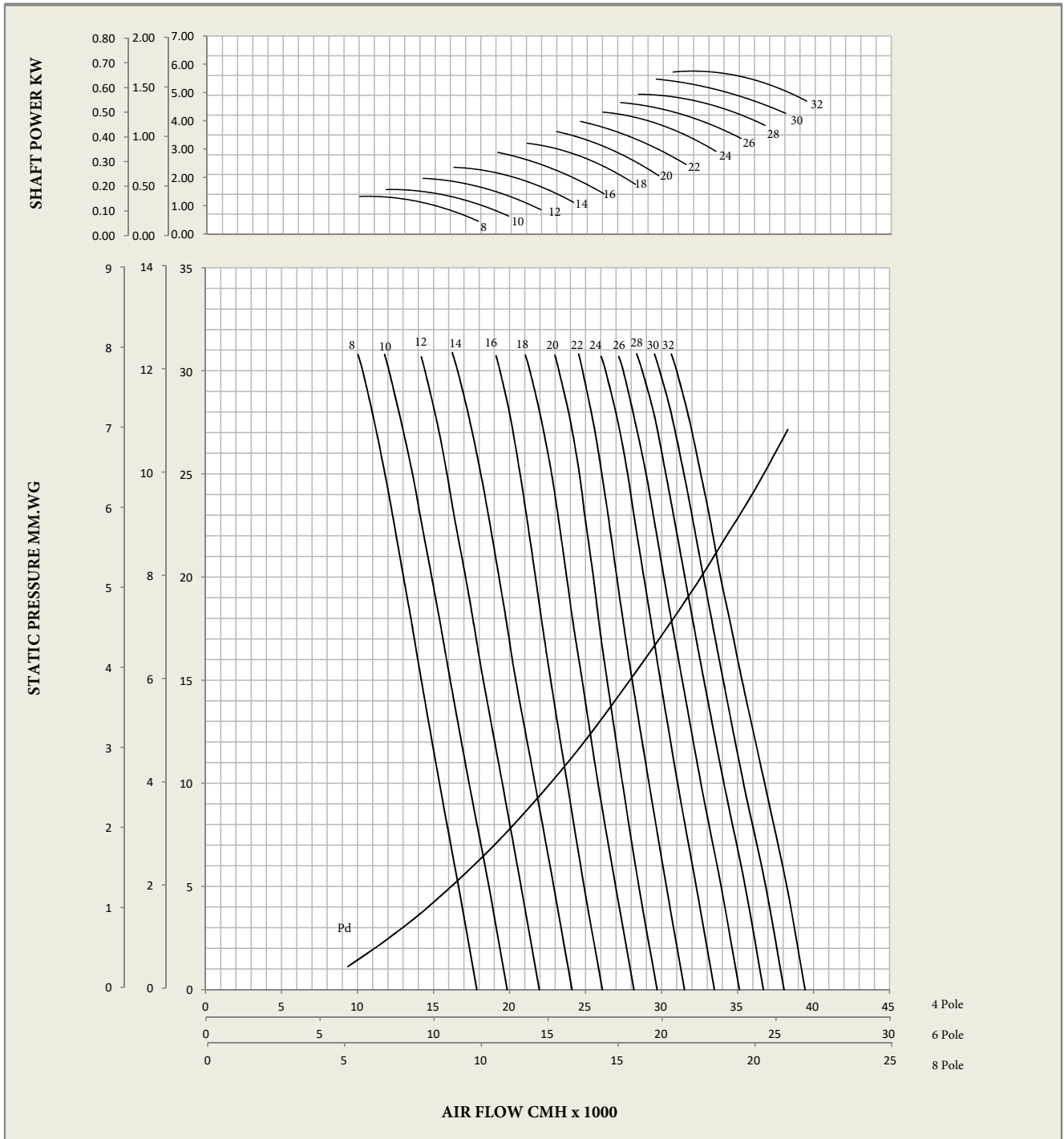

Sound Data (dBA)

Octave Bands	@ 20 Degree								@ 32 Degree									
	1	2	3	4	5	6	7	8	LWA	1	2	3	4	5	6	7	8	LWA
6 Pole	47	63	66	70	71	70	67	58	77	53	69	72	76	77	76	73	64	82
4 Pole	57	73	76	80	81	80	77	68	86	63	79	82	86	87	86	83	74	92

Motor Power (kW)

RPM	KW Max. L1/L2	Frame Size Max. L1/L2
8 Pole - 750	1.50/7.50	112/160
6 Pole - 950	2.20/11.0	112/160
4 Pole - 1450	4.00/15.0	112/160

Fan Performance is in accordance to **ISO 5801** (Fans - Performance testing using standardized airways). The impellers are tested according to the reduced tunnel method norm NFX 10-200. The sound levels are measured according to the NFS 31-021 norms.

AXF 800-9/50Hz

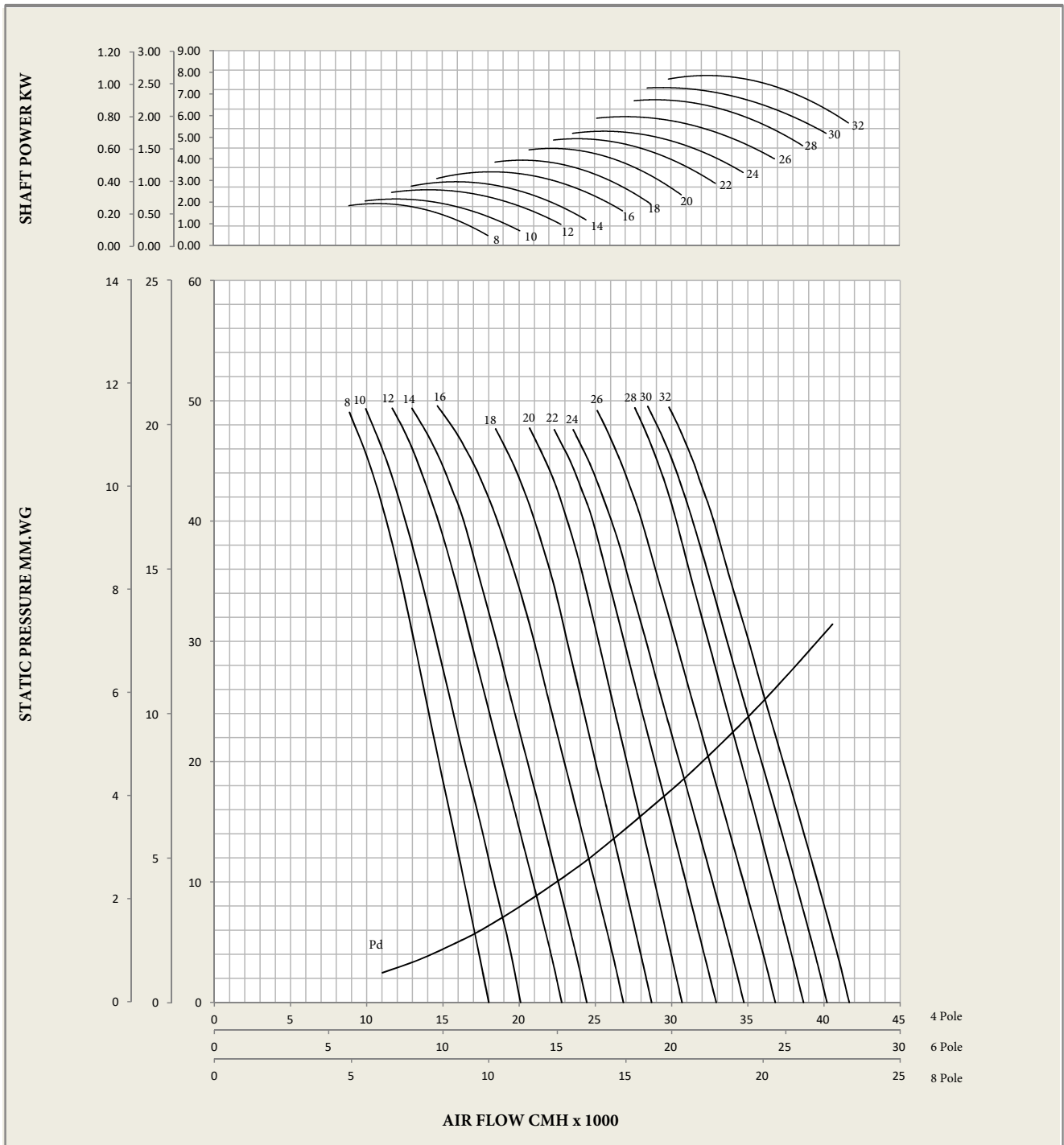

Sound Data (dBA)

Octave Bands	@ 20 Degree									@ 32 Degree								
	1	2	3	4	5	6	7	8	LWA	1	2	3	4	5	6	7	8	LWA
6 Pole	49	65	69	72	73	73	69	60	79	55	71	75	78	80	79	76	66	85
4 Pole	58	66	85	81	82	81	78	69	89	64	72	92	87	88	87	84	75	95

Motor Power (kW)

RPM	KW Max. L1/L2	Frame Size Max. L1/L2
8 Pole - 750	1.50/7.50	112/160
6 Pole - 950	2.20/11.0	112/160
4 Pole - 1450	4.00/15.0	112/160

Fan Performance is in accordance to **ISO 5801** (Fans - Performance testing using standardized airways). The impellers are tested according to the reduced tunnel method norm NFX 10-200. The sound levels are measured according to the NFS 31-021 norms.

AXF 900-3/50Hz

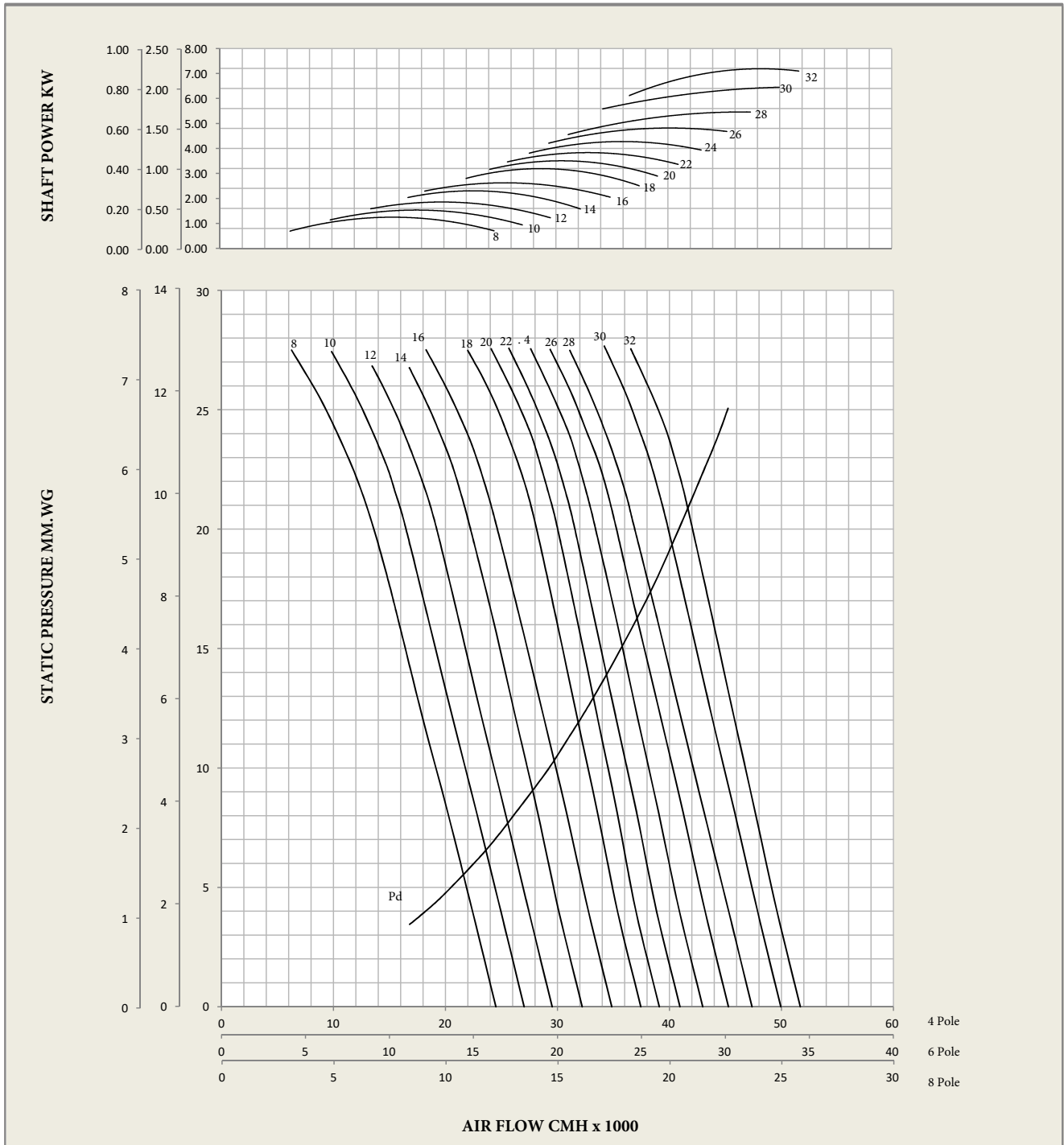

Sound Data (dBA)

Octave Bands	@ 20 Degree									@ 32 Degree								
	1	2	3	4	5	6	7	8	LWA	1	2	3	4	5	6	7	8	LWA
6 Pole	58	58	69	73	74	73	70	61	79	64	64	76	79	81	80	77	67	86
4 Pole	67	67	78	82	83	82	79	70	88	73	73	85	88	89	89	85	76	95

Motor Power (kW)

RPM	KW Max. L1/L2	Frame Size Max. L1/L2
8 Pole - 750	3.00/11.0	132/180
6 Pole - 950	5.50/15.0	132/180
4 Pole - 1450	7.50/22.0	132/180

Fan Performance is in accordance to **ISO 5801** (Fans - Performance testing using standardized airways). The impellers are tested according to the reduced tunnel method norm NFX 10-200. The sound levels are measured according to the NFS 31-021 norms.

AXF 900-6/50Hz

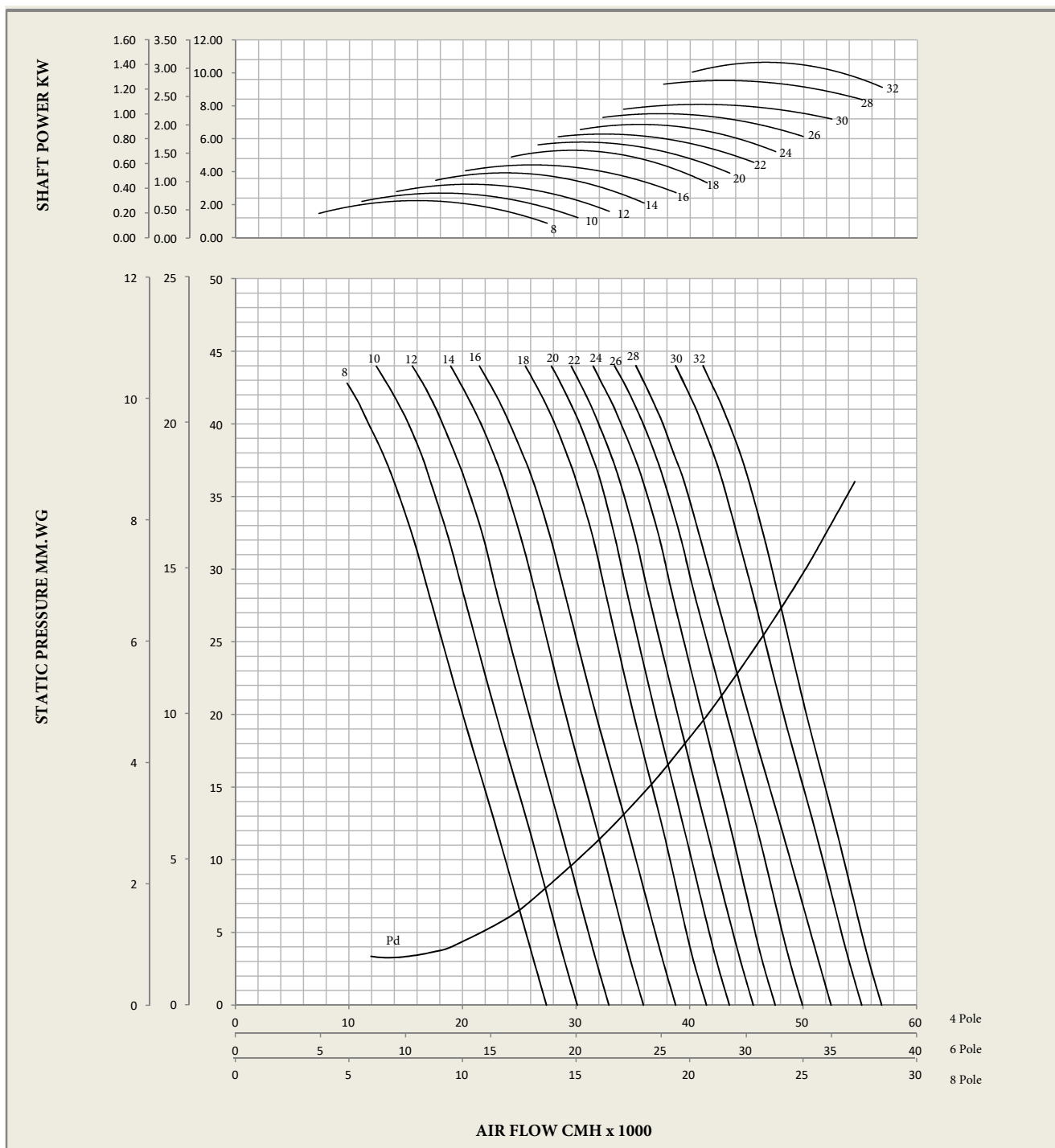

Sound Data (dBA)

Octave Bands	@ 20 Degree									@ 32 Degree								
	1	2	3	4	5	6	7	8	LWA	1	2	3	4	5	6	7	8	LWA
6 Pole	52	68	71	75	76	75	72	63	82	58	74	78	81	82	81	78	69	88
4 Pole	61	77	80	84	85	84	81	72	90	67	83	86	90	91	90	87	78	97

Motor Power (kW)

RPM	KW Max. L1/L2	Frame Size Max. L1/L2
8 Pole - 750	3.00/11.0	132/180
6 Pole - 950	5.50/15.0	132/180
4 Pole - 1450	7.50/22.0	132/180

Fan Performance is in accordance to **ISO 5801** (Fans - Performance testing using standardized airways). The impellers are tested according to the reduced tunnel method norm NFX 10-200. The sound levels are measured according to the NFS 31-021 norms.

AXF 900-9/50Hz

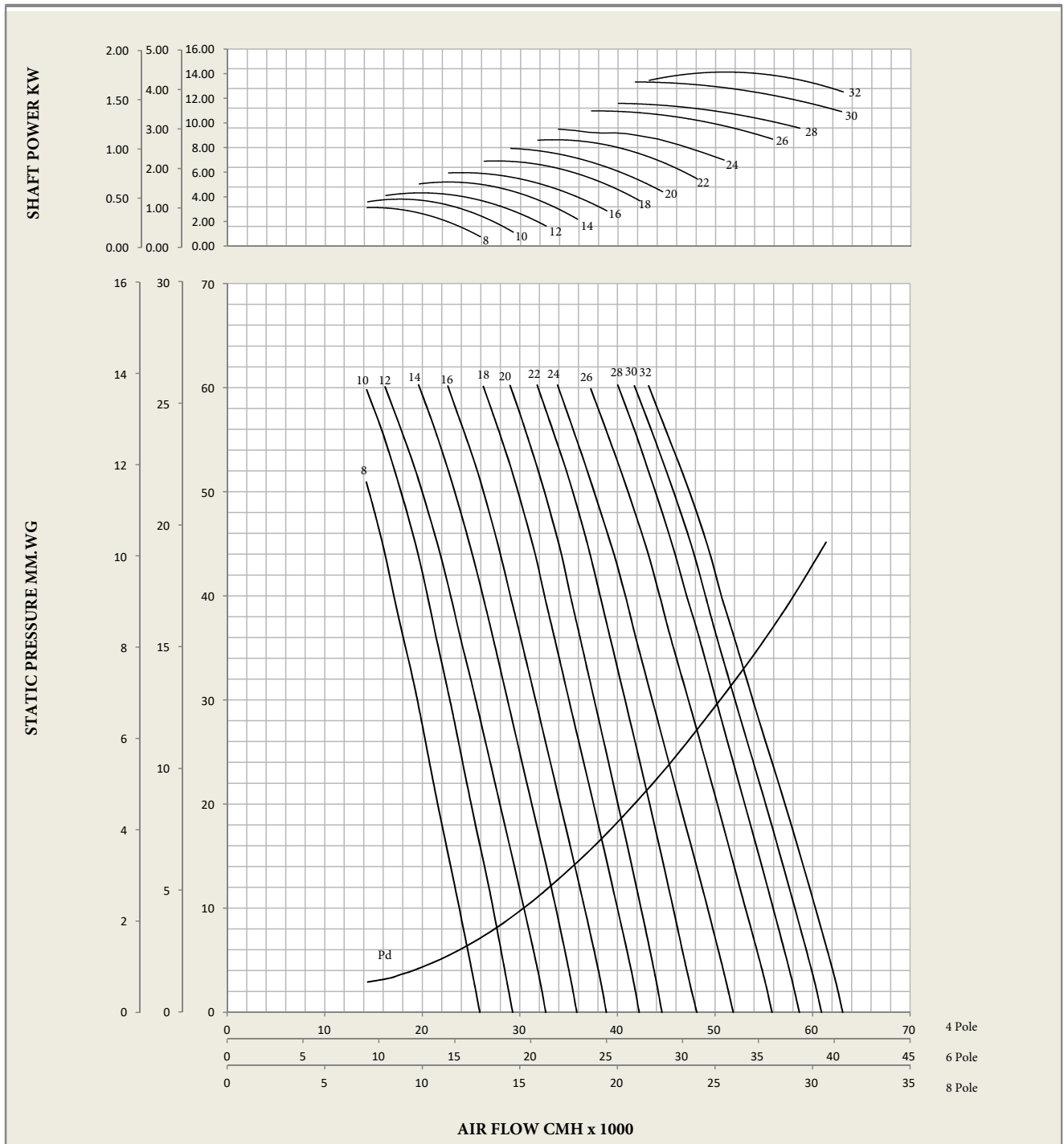

Sound Data (dBA)

Octave Bands	@ 20 Degree									@ 32 Degree								
	1	2	3	4	5	6	7	8	LWA	1	2	3	4	5	6	7	8	LWA
6 Pole	52	68	72	75	77	76	73	63	82	60	76	80	83	84	84	80	71	90
4 Pole	61	69	89	84	85	85	81	72	93	69	77	97	92	93	92	89	80	100

Motor Power (kW)

RPM	KW Max. L1/L2	Frame Size Max. L1/L2
8 Pole - 750	3.00/11.0	132/180
6 Pole - 950	5.50/15.0	132/180
4 Pole - 1450	7.50/22.0	132/180

Fan Performance is in accordance to **ISO 5801** (Fans - Performance testing using standardized airways). The impellers are tested according to the reduced tunnel method norm NFX 10-200. The sound levels are measured according to the NFS 31-021 norms.

AXF 1000-3/50Hz

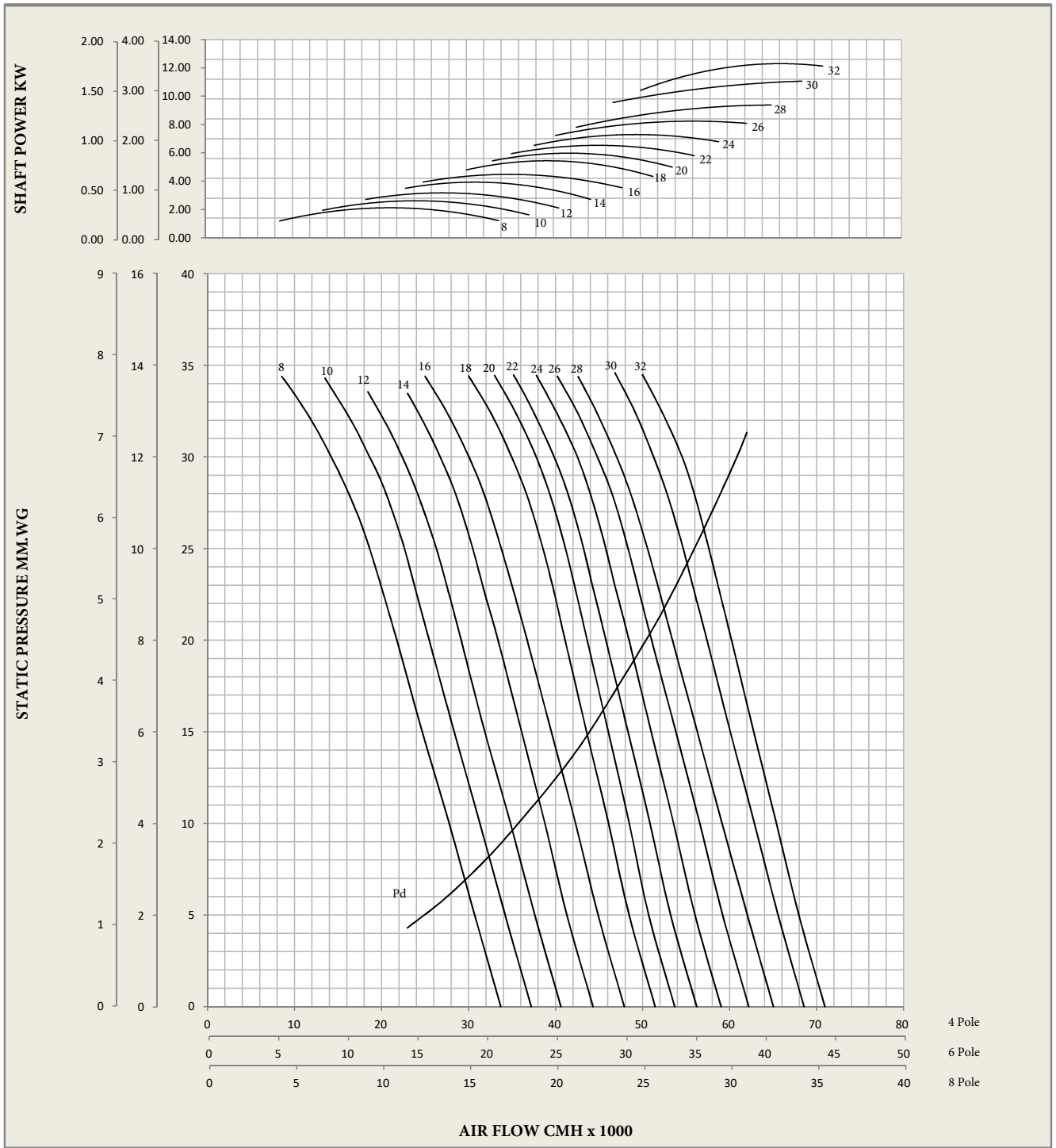

Sound Data (dBA)

Octave Bands	@ 20 Degree								@ 32 Degree									
	1	2	3	4	5	6	7	8	LWA	1	2	3	4	5	6	7	8	LWA
6 Pole	61	61	73	76	77	76	73	64	83	67	67	79	82	84	83	80	70	89
4 Pole	70	70	81	85	86	85	82	73	91	76	76	88	91	93	92	89	79	98

Motor Power (kW)

RPM	KW Max. L1/L2	Frame Size Max. L1/L2
8 Pole - 750	3.00/15.0	132/200
6 Pole - 950	5.50/22.0	132/200
4 Pole - 1450	7.50/30.0	132/200

Fan Performance is in accordance to **ISO 5801** (Fans - Performance testing using standardized airways).The impellers are tested according to the reduced tunnel method norm NFX 10-200.The sound levels are measured according to the NFS 31-021 norms.

AXF 1000-6/50Hz

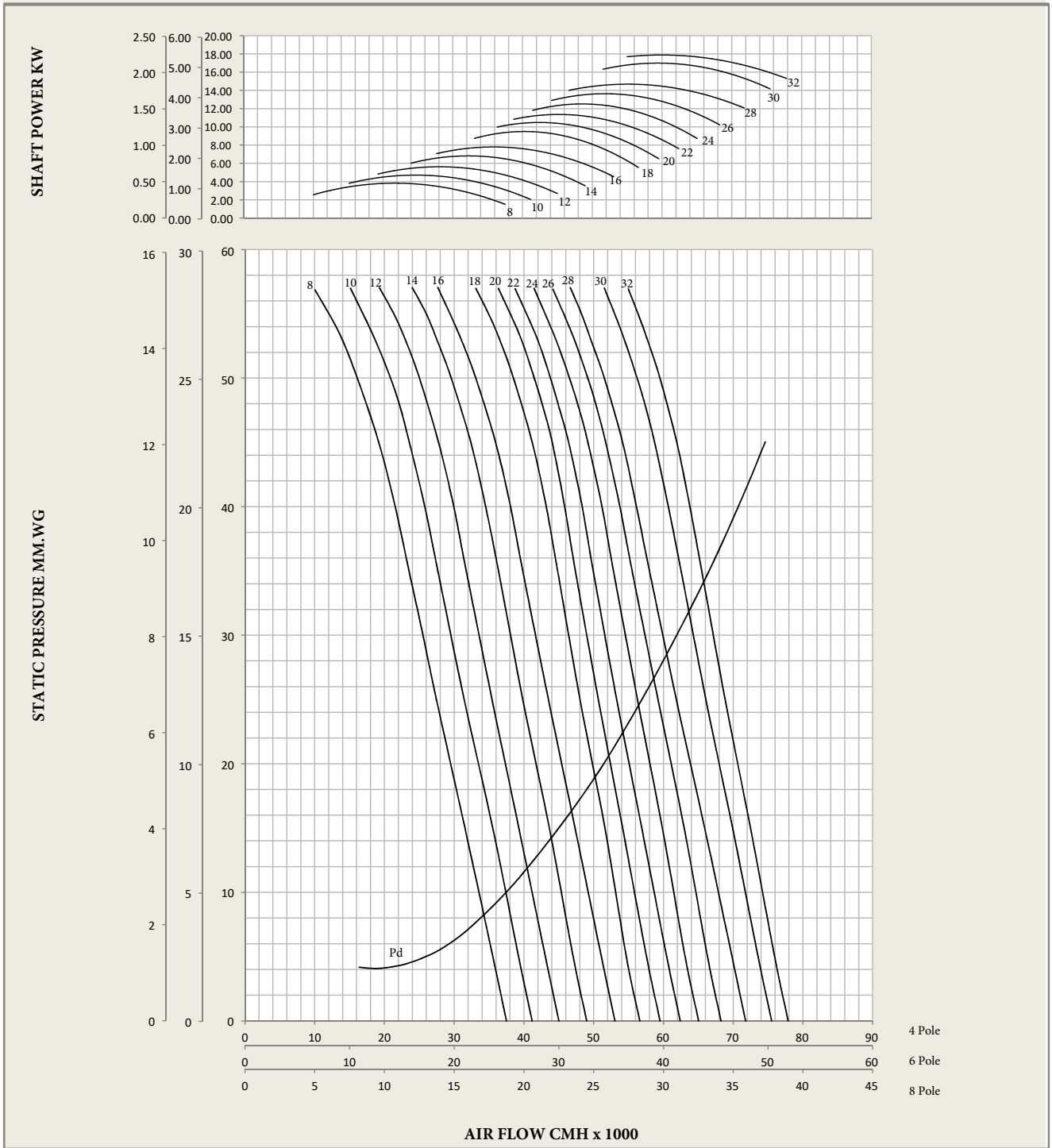

Sound Data (dBA)

Octave Bands	@ 20 Degree									@ 32 Degree								
	1	2	3	4	5	6	7	8	LWA	1	2	3	4	5	6	7	8	LWA
6 Pole	55	71	75	78	79	79	75	66	85	61	77	81	84	86	85	82	72	91
4 Pole	64	80	84	87	88	87	84	75	94	70	86	90	93	94	94	90	81	100

Motor Power (kW)

RPM	KW Max. L1/L2	Frame Size Max. L1/L2
8 Pole - 750	3.00/15.0	132/200
6 Pole - 950	5.50/22.0	132/200
4 Pole - 1450	7.50/30.0	132/200

Fan Performance is in accordance to **ISO 5801** (Fans - Performance testing using standardized airways). The impellers are tested according to the reduced tunnel method norm NFX 10-200. The sound levels are measured according to the NFS 31-021 norms.

AXF 1000-9/50Hz

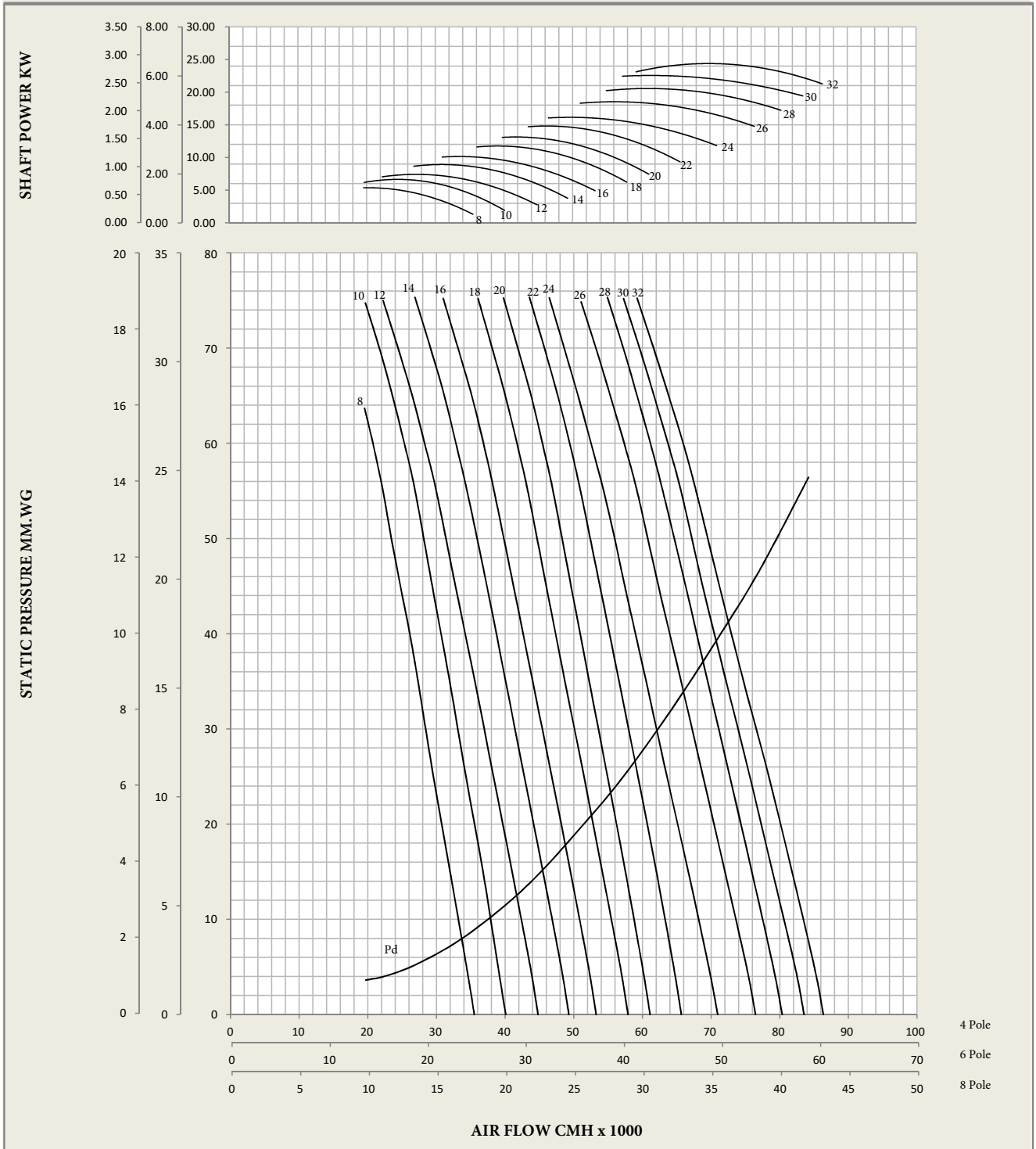

Sound Data (dBA)

Octave Bands	@ 20 Degree									@ 32 Degree								
	1	2	3	4	5	6	7	8	LWA	1	2	3	4	5	6	7	8	LWA
6 Pole	56	72	75	79	80	79	76	67	85	64	80	83	87	88	87	84	75	93
4 Pole	64	73	92	87	89	88	85	76	96	72	80	100	95	96	96	92	83	104

Motor Power (kW)

RPM	KW Max. L1/L2	Frame Size Max. L1/L2
8 Pole - 750	3.00/15.0	132/200
6 Pole - 950	5.50/22.0	132/200
4 Pole - 1450	7.50/30.0	132/200

Fan Performance is in accordance to **ISO 5801** (Fans - Performance testing using standardized airways). The impellers are tested according to the reduced tunnel method norm NFX 10-200. The sound levels are measured according to the NFS 31-021 norms.

AXF 1120-3/50Hz

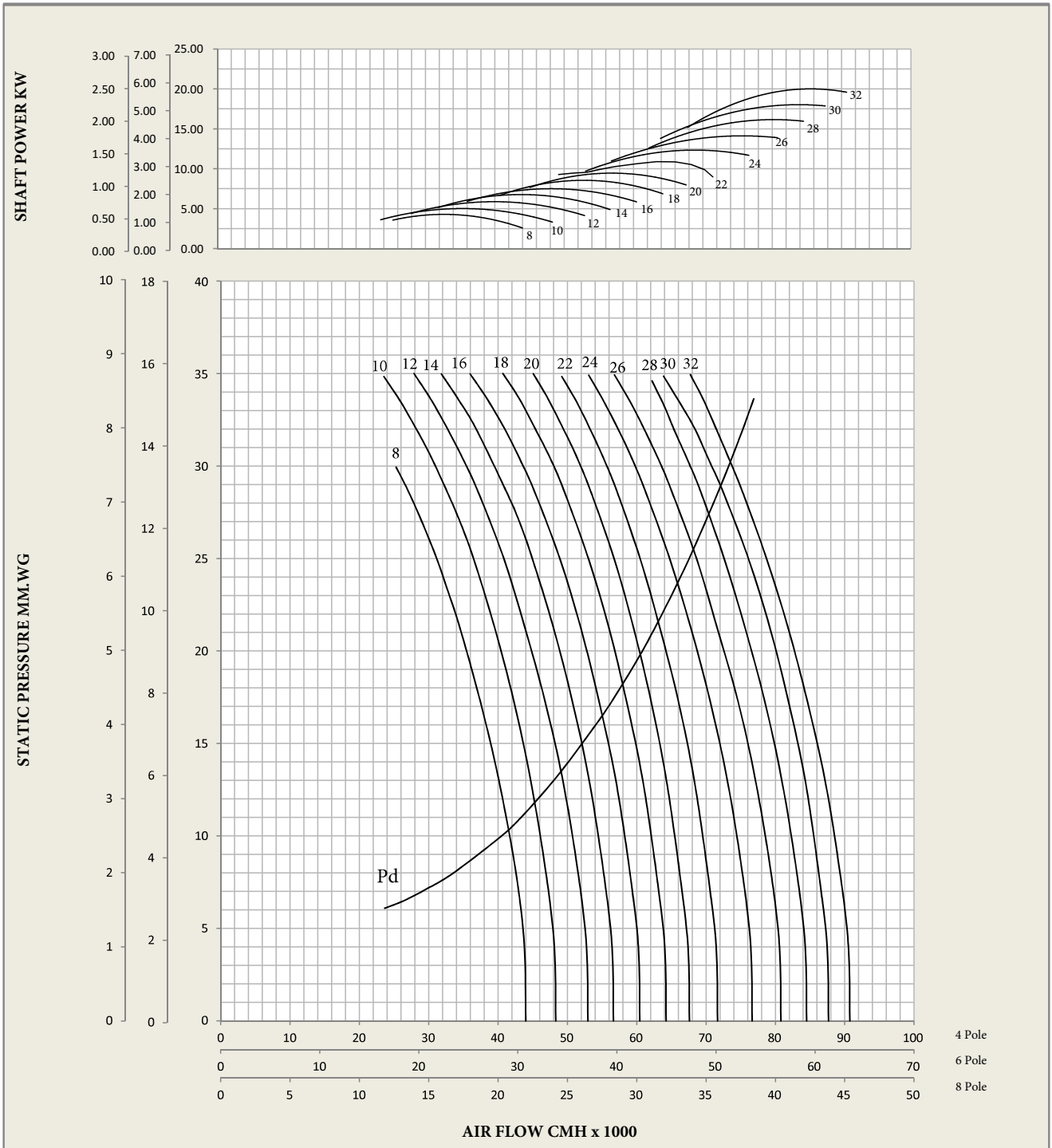

Sound Data (dBA)

Octave Bands	@ 20 Degree									@ 32 Degree								
	1	2	3	4	5	6	7	8	LWA	1	2	3	4	5	6	7	8	LWA
6 Pole	63	63	74	78	79	78	75	66	84	70	70	82	85	86	86	82	73	92
4 Pole	72	72	83	87	88	87	84	75	93	79	79	91	94	95	94	91	82	100

Motor Power (kW)

RPM	KW Max. L1/L2	Frame Size Max. L1/L2
8 Pole - 750	7.5.00/22.0	160/225
6 Pole - 950	11.00/30.0	160/225
4 Pole - 1450	15.0/45.0	160/225

Fan Performance is in accordance to **ISO 5801** (Fans - Performance testing using standardized airways).The impellers are tested according to the reduced tunnel method norm NFX 10-200.The sound levels are measured according to the NFS 31-021 norms.

AXF 1120-6/50Hz

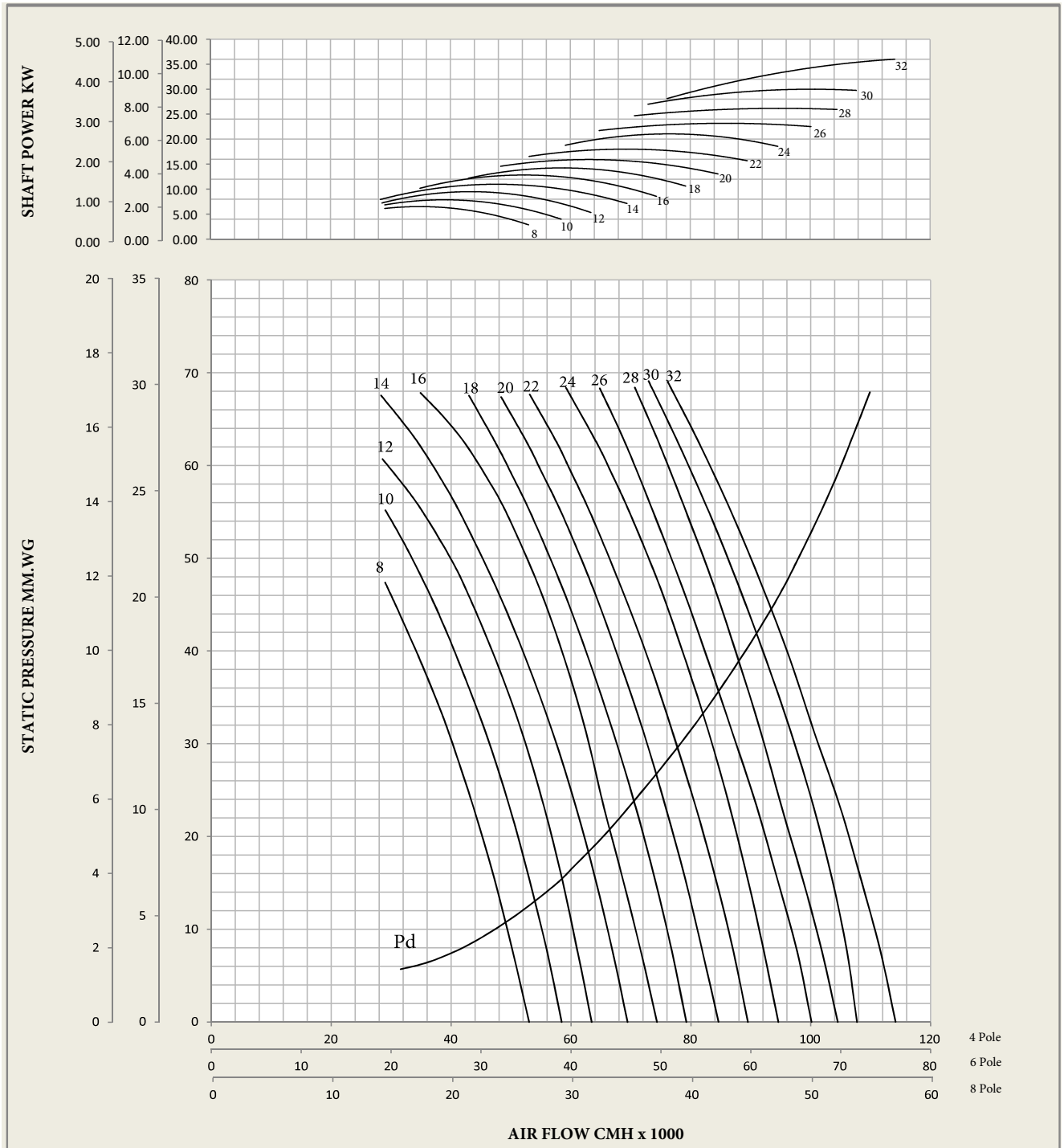

Sound Data (dBA)

Octave Bands	@ 20 Degree									@ 32 Degree								
	1	2	3	4	5	6	7	8	LWA	1	2	3	4	5	6	7	8	LWA
6 Pole	59	75	79	82	83	82	79	70	89	66	82	85	89	90	89	86	77	95
4 Pole	68	84	87	91	92	91	88	79	98	76	92	95	99	100	99	96	87	105

Motor Power (kW)

RPM	KW Max. L1/L2	Frame Size Max. L1/L2
8 Pole - 750	7.500/22.0	160/225
6 Pole - 950	11.00/30.0	160/225
4 Pole - 1450	15.0/45.0	160/225

Fan Performance is in accordance to **ISO 5801** (Fans - Performance testing using standardized airways). The impellers are tested according to the reduced tunnel method norm NFX 10-200. The sound levels are measured according to the NFS 31-021 norms.

AXF 1120-9/50Hz

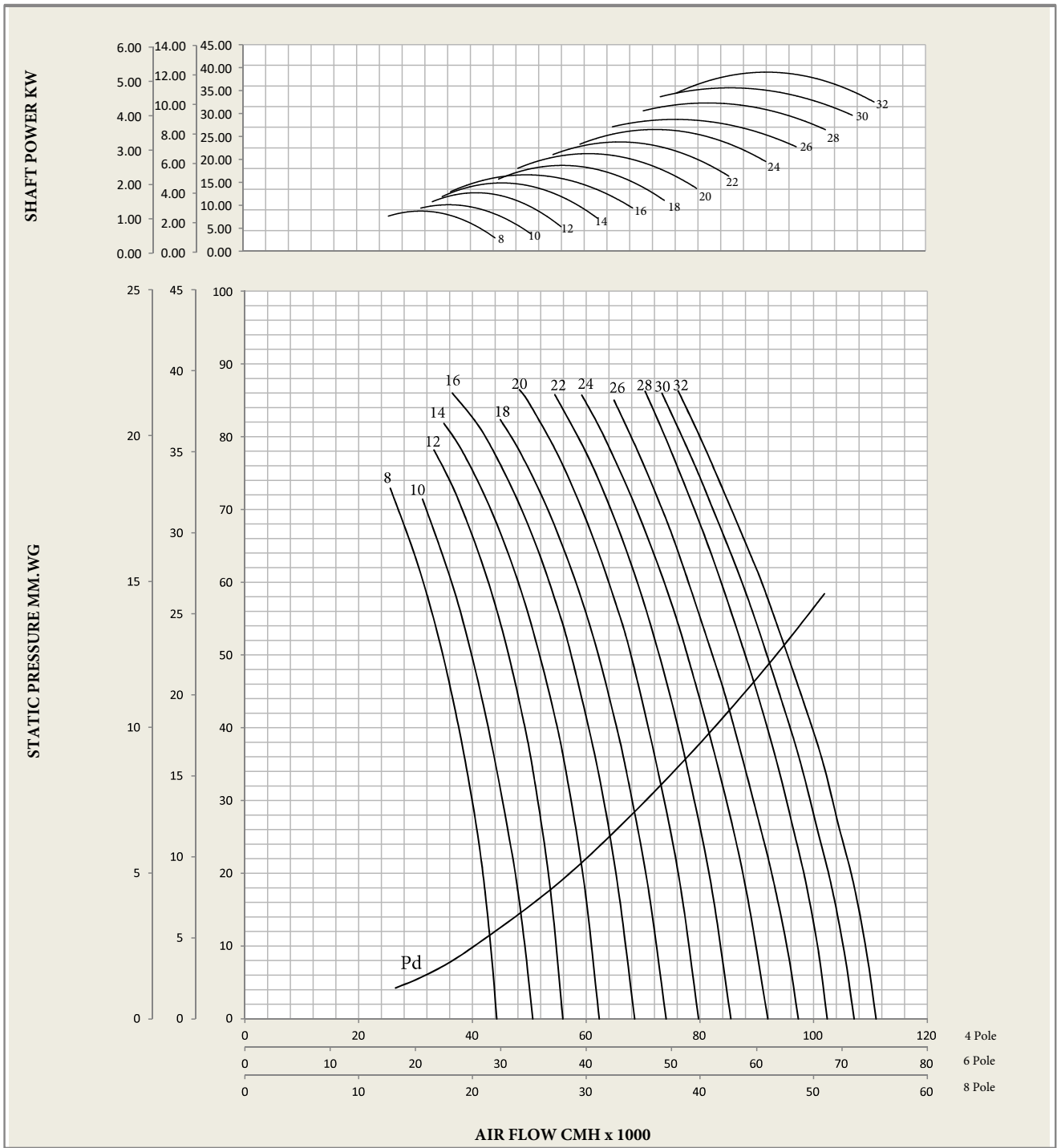

Sound Data (dBA)

Octave Bands	@ 20 Degree									@ 32 Degree								
	1	2	3	4	5	6	7	8	LWA	1	2	3	4	5	6	7	8	LWA
6 Pole	59	75	79	82	83	83	79	70	89	66	82	85	89	90	89	86	77	95
4 Pole	68	76	96	91	92	91	88	79	99	75	83	102	98	99	98	95	86	106

Motor Power (kW)

RPM	KW Max. L1/L2	Frame Size Max. L1/L2
8 Pole - 750	7.500/22.0	160/225
6 Pole - 950	11.00/30.0	160/225
4 Pole - 1450	15.0/45.0	160/225

Fan Performance is in accordance to **ISO 5801** (Fans - Performance testing using standardized airways). The impellers are tested according to the reduced tunnel method norm NFX 10-200. The sound levels are measured according to the NFS 31-021 norms.

AXF 1250-3/50Hz

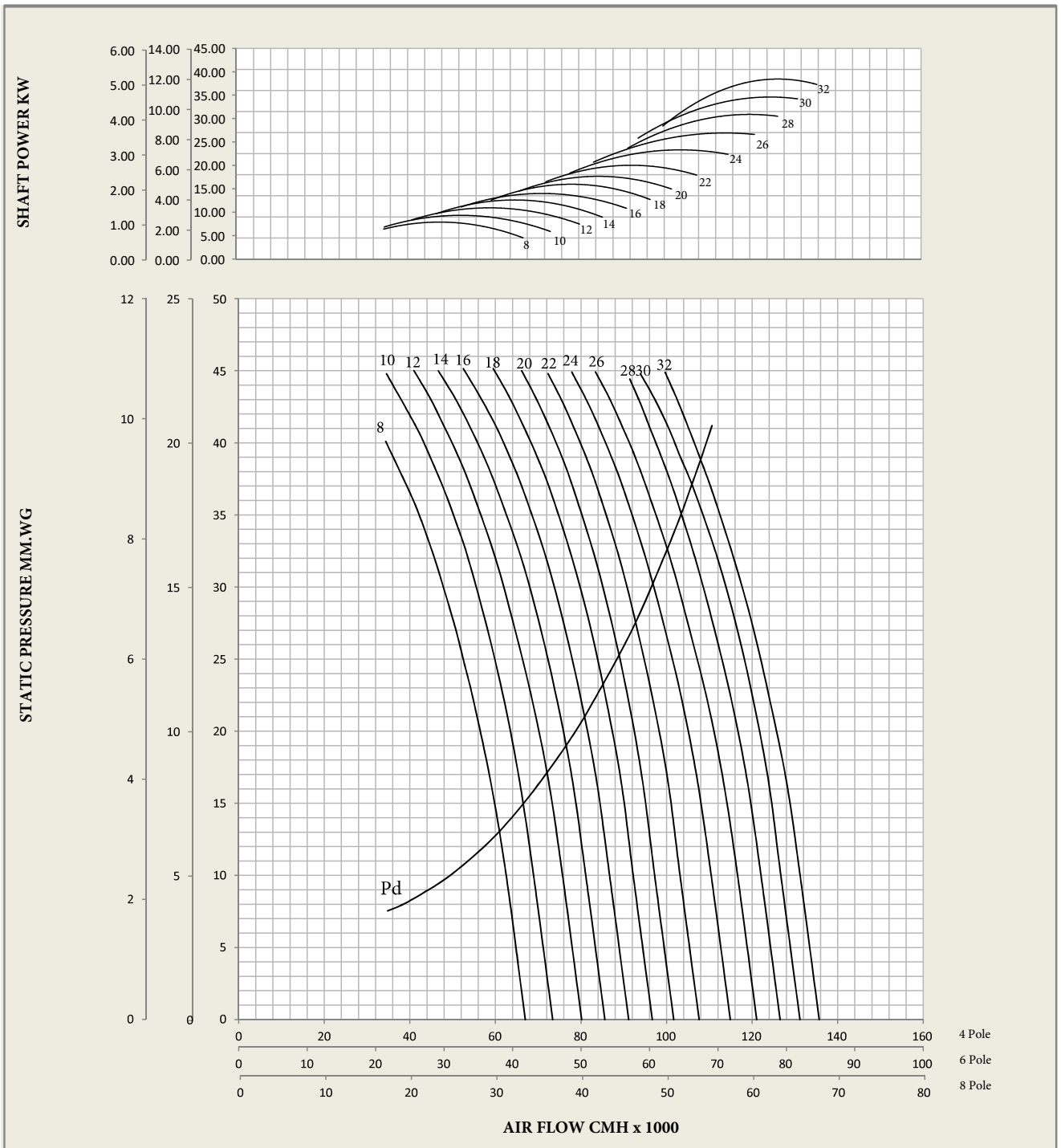

Sound Data (dBA)

Octave Bands	@ 20 Degree									@ 32 Degree								
	1	2	3	4	5	6	7	8	LWA	1	2	3	4	5	6	7	8	LWA
6 Pole	67	67	79	82	83	82	79	70	88	74	74	85	89	90	89	86	77	95
4 Pole	76	76	88	91	92	91	88	79	98	83	83	94	98	99	98	95	86	104

Motor Power (kW)

RPM	KW Max. L1/L2	Frame Size Max. L1/L2
8 Pole - 750	7.5.00/45.0	160/280
6 Pole - 950	11.00/55.0	160/280
4 Pole - 1450	15.0/75.0	160/280

Fan Performance is in accordance to **ISO 5801** (Fans - Performance testing using standardized airways).The impellers are tested according to the reduced tunnel method norm NFX 10-200.The sound levels are measured according to the NFS 31-021 norms.

AXF 1250-6/50Hz

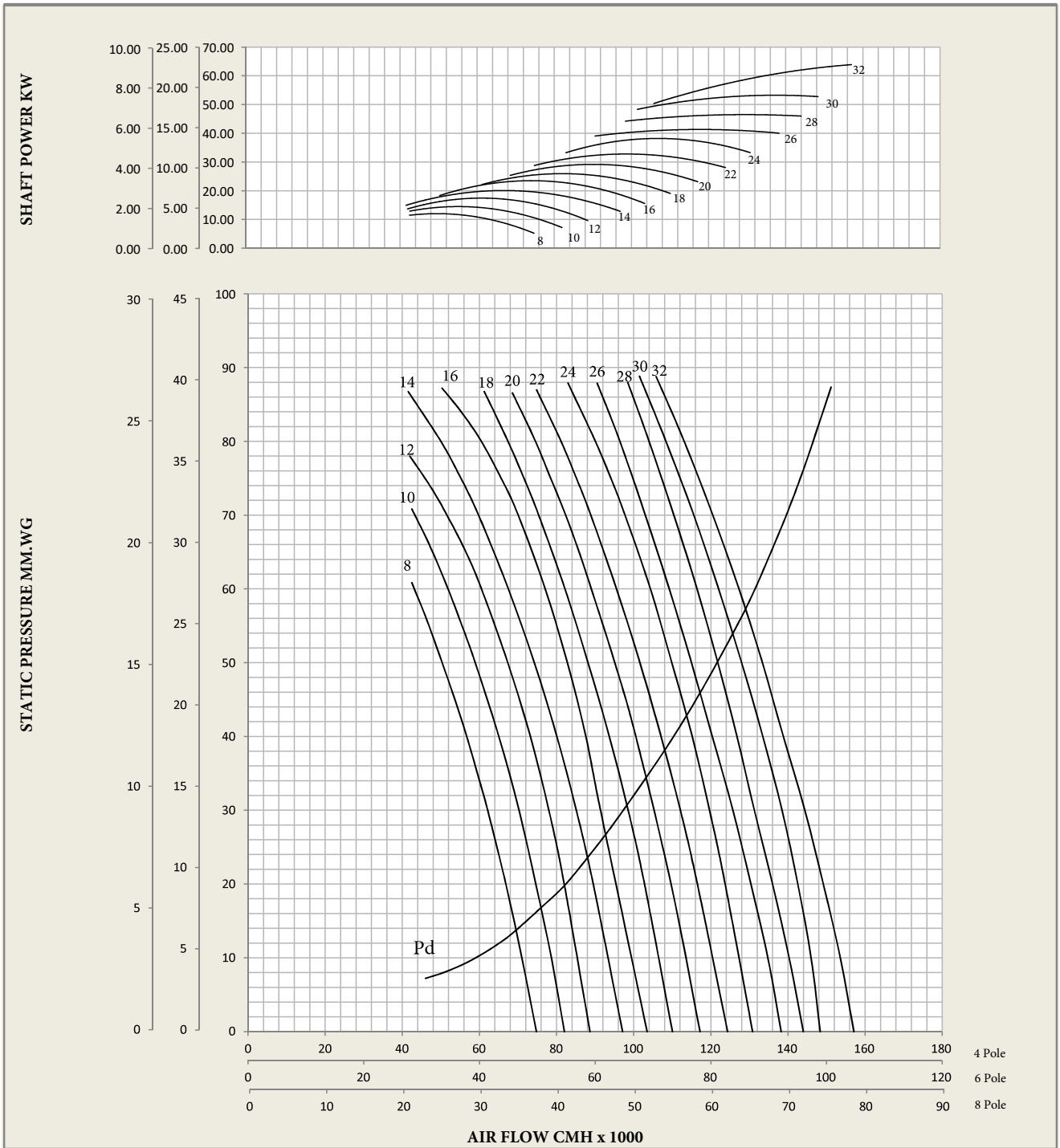

Sound Data (dBA)

Octave Bands	@ 20 Degree									@ 32 Degree								
	1	2	3	4	5	6	7	8	LWA	1	2	3	4	5	6	7	8	LWA
6 Pole	63	79	83	86	87	86	83	74	93	69	85	89	92	93	93	89	80	99
4 Pole	71	88	91	94	96	95	92	83	101	78	94	97	101	102	101	98	89	107

Motor Power (kW)

RPM	KW Max. L1/L2	Frame Size Max. L1/L2
8 Pole - 750	7.500/45.0	160/280
6 Pole - 950	11.00/55.0	160/280
4 Pole - 1450	15.0/75.0	160/280

Fan Performance is in accordance to **ISO 5801** (Fans - Performance testing using standardized airways). The impellers are tested according to the reduced tunnel method norm NFX 10-200. The sound levels are measured according to the NFS 31-021 norms.

AXF 1250-9/50Hz

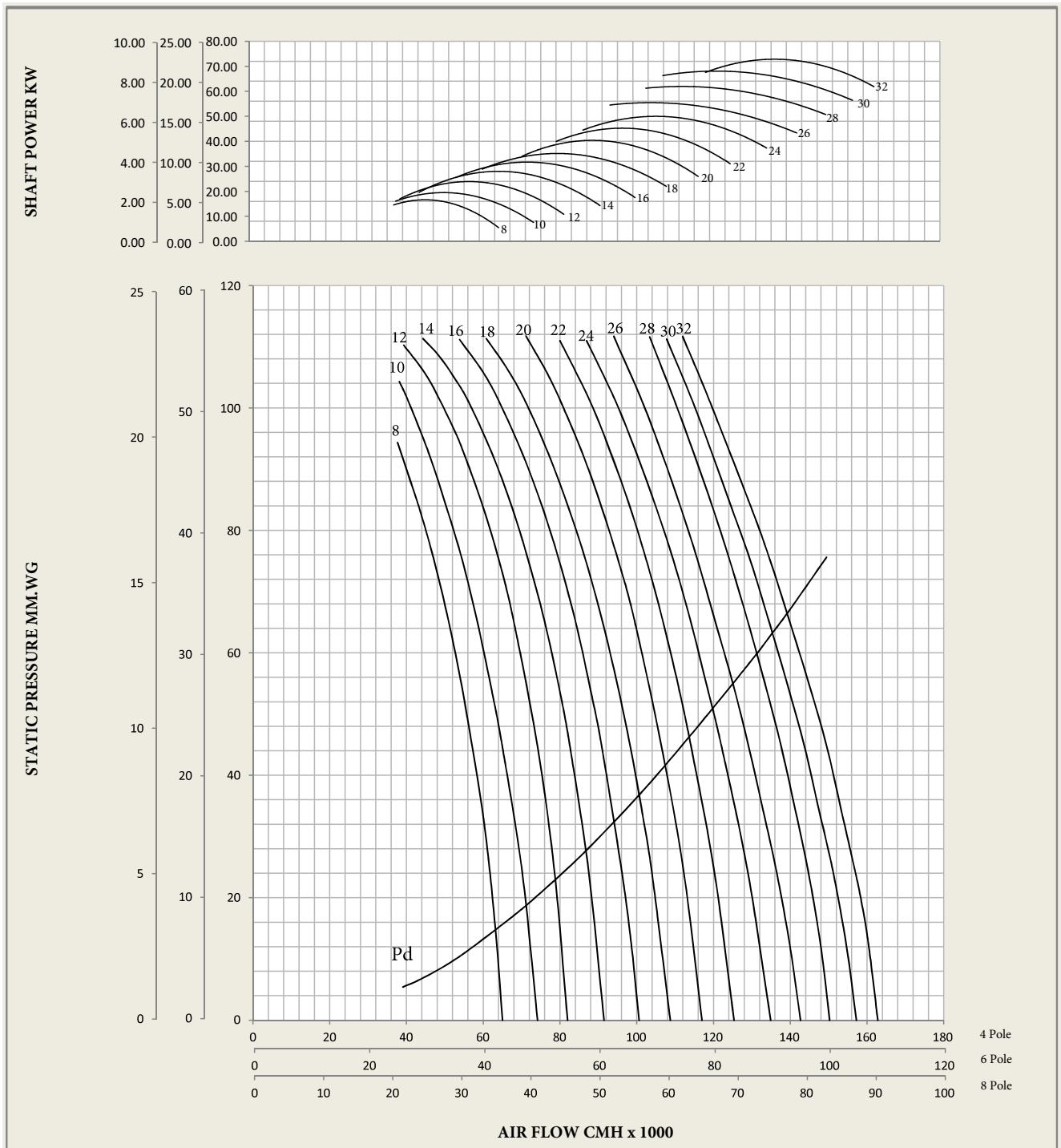

Sound Data (dBA)

Octave Bands	@ 20 Degree									@ 32 Degree								
	1	2	3	4	5	6	7	8	LWA	1	2	3	4	5	6	7	8	LWA
6 Pole	63	79	83	86	87	87	83	74	93	70	86	89	93	94	93	90	81	99
4 Pole	72	80	100	95	96	95	92	83	103	77	85	105	100	101	100	97	88	108

Motor Power (kW)

RPM	KW Max. L1/L2	Frame Size Max. L1/L2
8 Pole - 750	7.5.00/45.0	160/280
6 Pole - 950	11.00/55.0	160/280
4 Pole - 1450	15.0/75.0	160/280

Fan Performance is in accordance to **ISO 5801** (Fans - Performance testing using standardized airways). The impellers are tested according to the reduced tunnel method norm NFX 10-200. The sound levels are measured according to the NFS 31-021 norms.

AXF 1400-3/50Hz

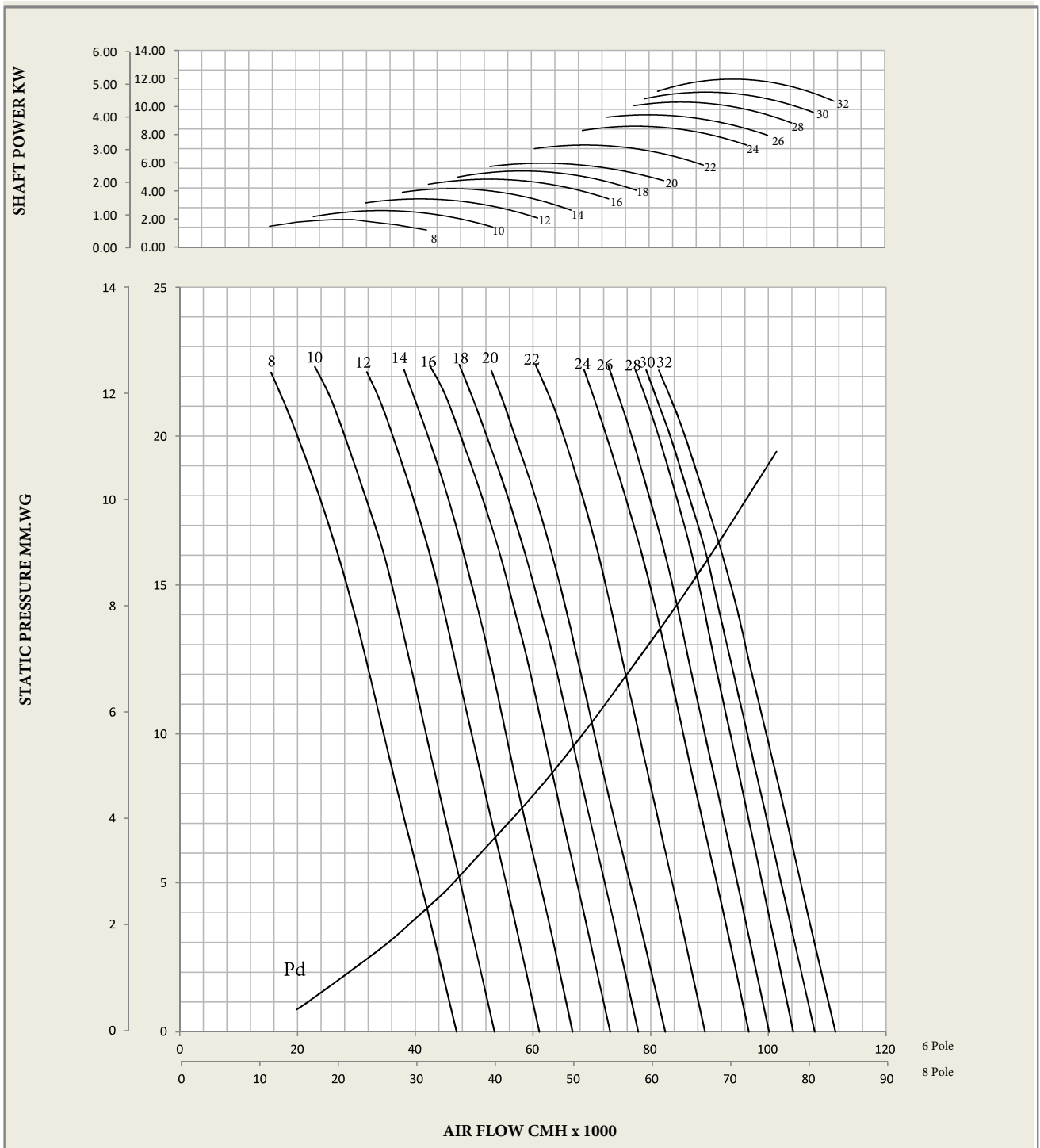

Sound Data (dBA)

Octave Bands	@ 20 Degree									@ 32 Degree								
	1	2	3	4	5	6	7	8	LWA	1	2	3	4	5	6	7	8	LWA
6 Pole	67	67	79	82	84	83	80	70	89	73	73	85	88	89	88	85	76	95

Motor Power (kW)

RPM	KW Max. L2	Frame Size Max. L2
8 Pole - 750	45.0	280
6 Pole - 950	55.0	280

Fan Performance is in accordance to **ISO 5801** (Fans - Performance testing using standardized airways). The impellers are tested according to the reduced tunnel method norm NFX 10-200. The sound levels are measured according to the NFS 31-021 norms.

AXF 1400-6/50Hz

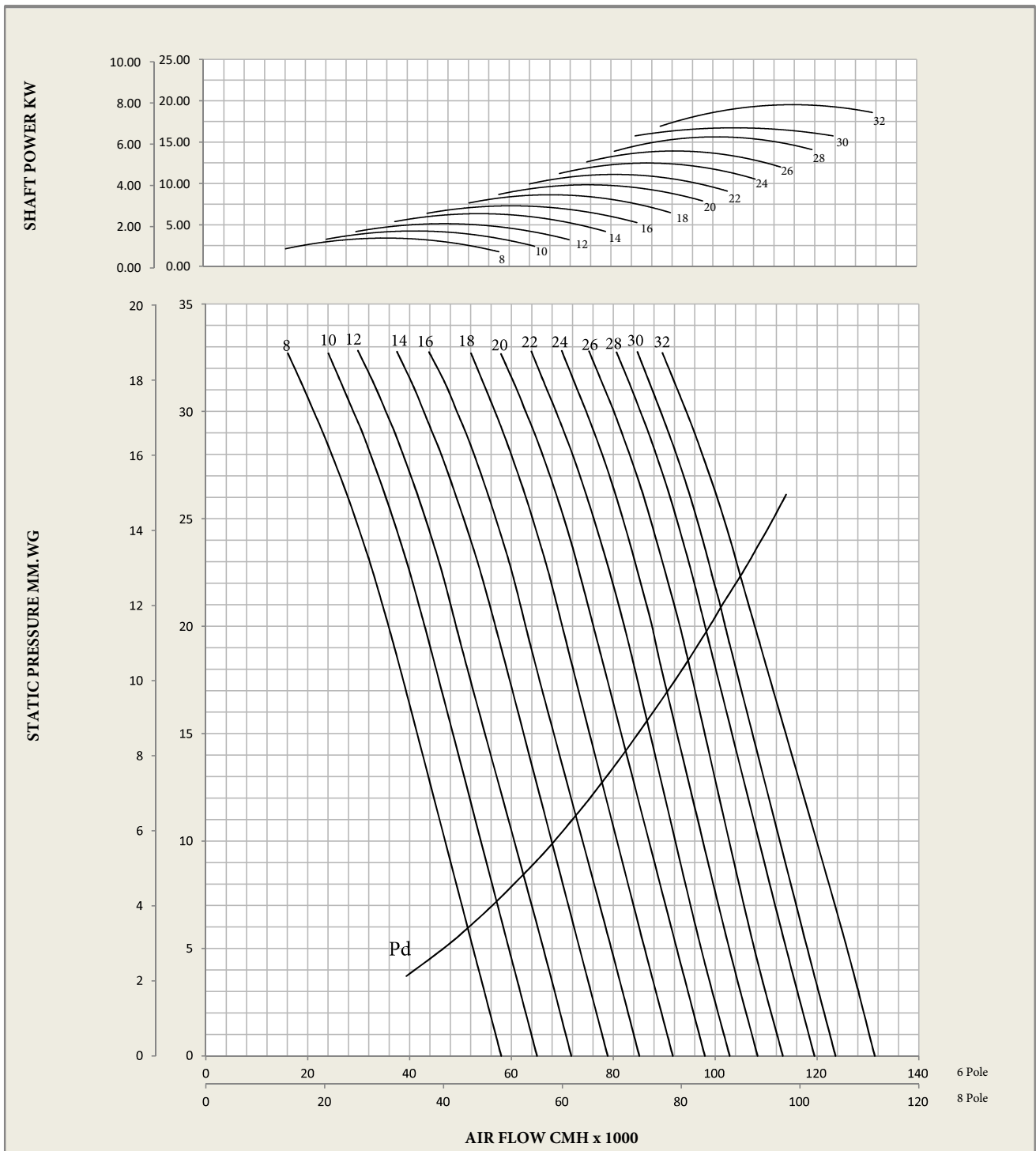

Sound Data (dBA)

Octave Bands	@ 20 Degree									@ 32 Degree								
	1	2	3	4	5	6	7	8	LWA	1	2	3	4	5	6	7	8	LWA
6 Pole	63	79	83	86	87	87	83	74	93	69	86	89	92	94	93	90	81	99

Motor Power (kW)

RPM	KW Max. L2	Frame Size Max. L2
8 Pole - 750	45.0	280
6 Pole - 950	55.0	280

Fan Performance is in accordance to **ISO 5801** (Fans - Performance testing using standardized airways).The impellers are tested according to the reduced tunnel method norm NFX 10-200.The sound levels are measured according to the NFS 31-021 norms.

AXF 1400-9/50Hz

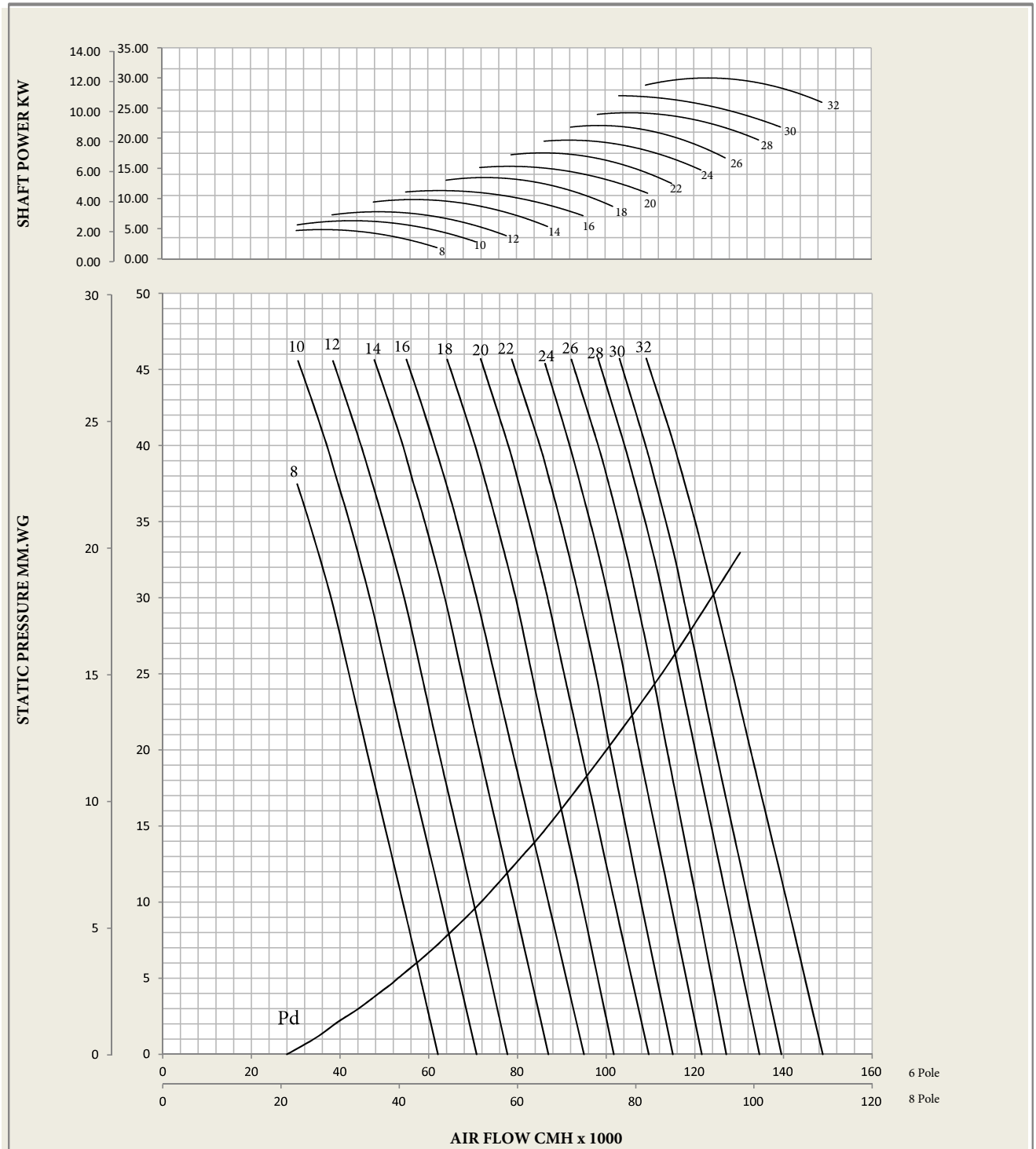

Sound Data (dBA)

Octave Bands	@ 20 Degree									@ 32 Degree								
	1	2	3	4	5	6	7	8	LWA	1	2	3	4	5	6	7	8	LWA
6 Pole	65	81	85	88	90	89	86	76	95	72	88	91	95	96	95	92	83	101

Motor Power (kW)

RPM	KW Max. L2	Frame Size Max. L2
8 Pole - 750	45.0	280
6 Pole - 950	55.0	280

Fan Performance is in accordance to **ISO 5801** (Fans - Performance testing using standardized airways). The impellers are tested according to the reduced tunnel method norm NFX 10-200. The sound levels are measured according to the NFS 31-021 norms.

AXF 1600-3/50Hz

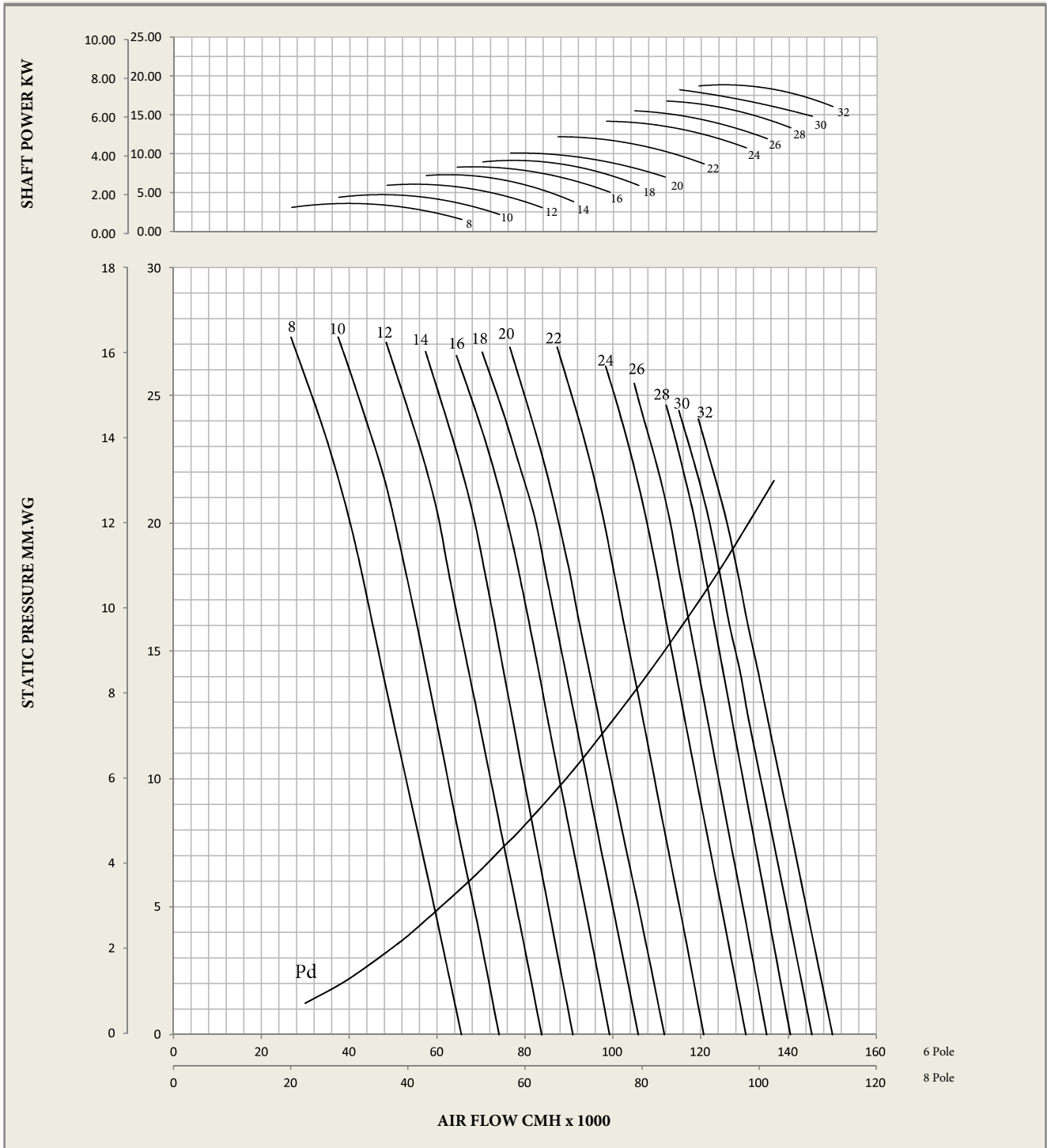

Sound Data (dBA)

Octave Bands	@ 20 Degree									@ 32 Degree								
	1	2	3	4	5	6	7	8	LWA	1	2	3	4	5	6	7	8	LWA
6 Pole	69	70	81	84	86	85	82	73	91	75	76	87	90	92	91	88	79	97

Motor Power (kW)

RPM	KW Max. L2	Frame Size Max. L2
8 Pole - 750	45.0	315
6 Pole - 950	55.0	315

Fan Performance is in accordance to **ISO 5801** (Fans - Performance testing using standardized airways).The impellers are tested according to the reduced tunnel method norm NFX 10-200.The sound levels are measured according to the NFS 31-021 norms.

AXF 1600-6/50Hz

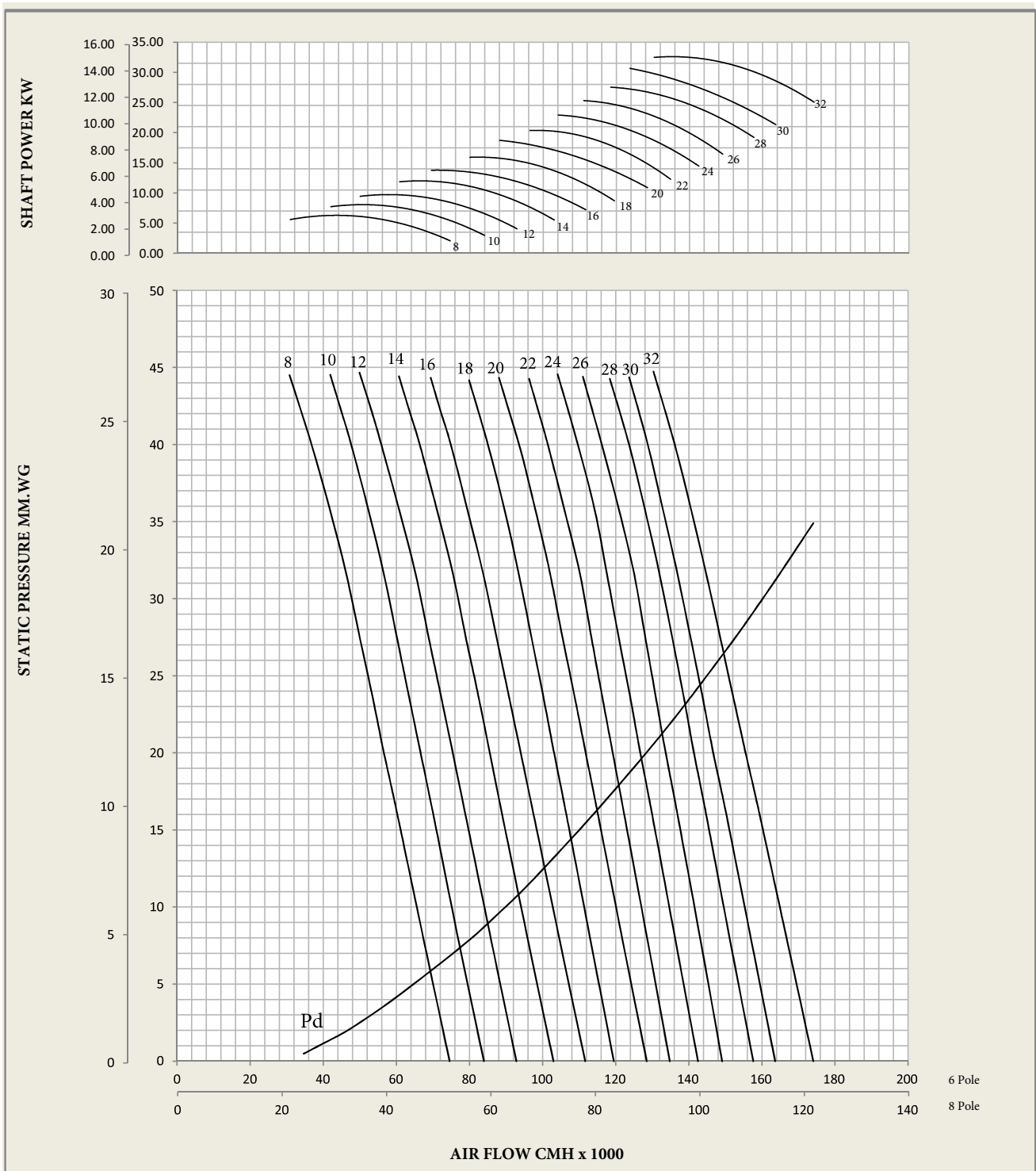

Sound Data (dBA)

Octave Bands	@ 20 Degree									@ 32 Degree								
	1	2	3	4	5	6	7	8	LWA	1	2	3	4	5	6	7	8	LWA
6 Pole	65	81	84	88	89	88	85	76	94	71	87	90	94	95	94	91	82	100

Motor Power (kW)

RPM	KW Max. L2	Frame Size Max. L2
8 Pole - 750	45.0	315
6 Pole - 950	55.0	315

Fan Performance is in accordance to **ISO 5801** (Fans - Performance testing using standardized airways). The impellers are tested according to the reduced tunnel method norm NFX 10-200. The sound levels are measured according to the NFS 31-021 norms.

AXF 1600-9/50Hz

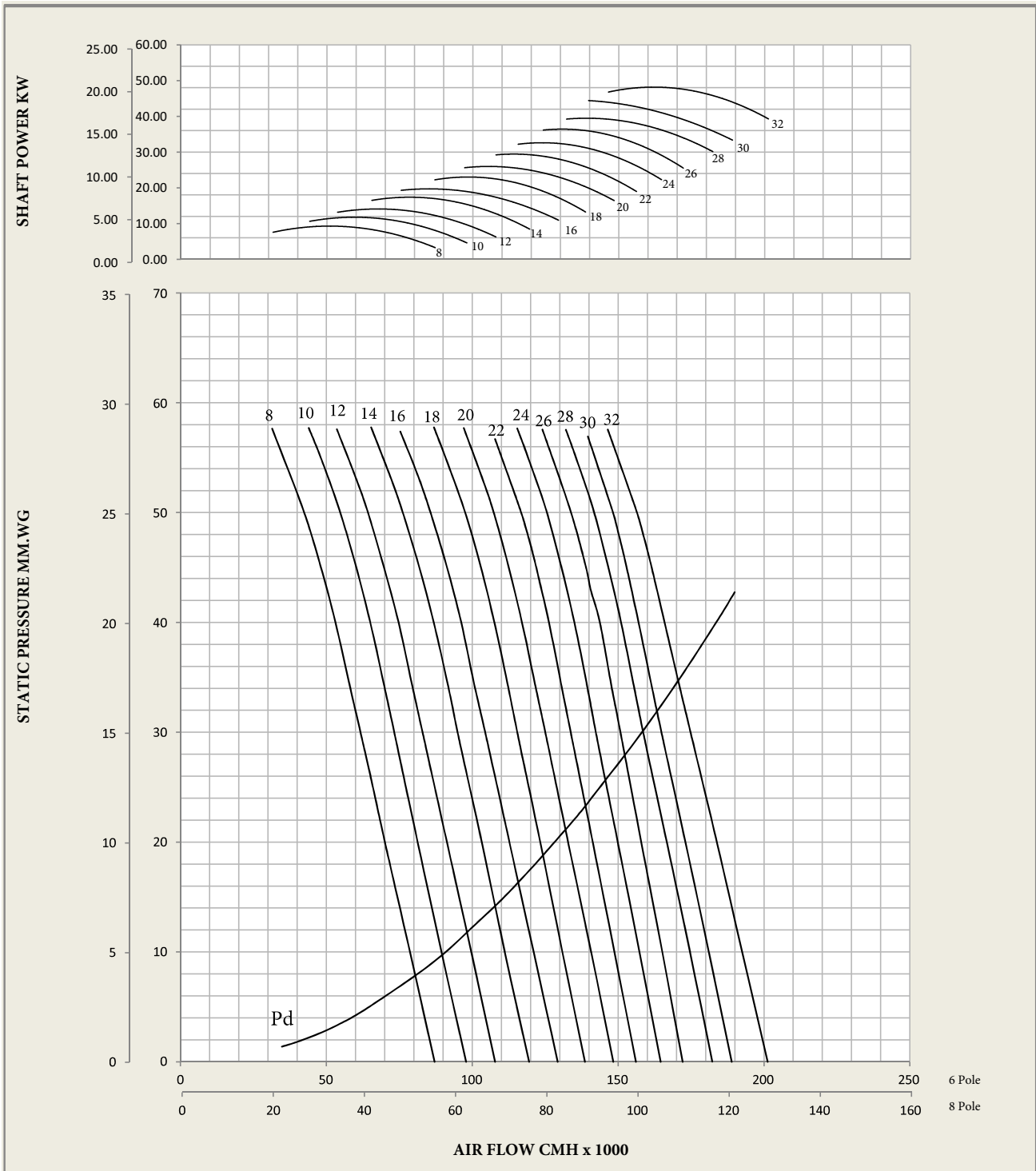

Sound Data (dBA)

Octave Bands	@ 20 Degree									@ 32 Degree								
	1	2	3	4	5	6	7	8	LWA	1	2	3	4	5	6	7	8	LWA
6 Pole	68	84	87	91	92	91	88	79	97	74	90	94	97	98	97	94	85	104

Motor Power (kW)

RPM	KW Max. L2	Frame Size Max. L2
8 Pole - 750	45.0	315
6 Pole - 950	75.0	315

Fan Performance is in accordance to **ISO 5801** (Fans - Performance testing using standardized airways). The impellers are tested according to the reduced tunnel method norm NFX 10-200. The sound levels are measured according to the NFS 31-021 norms.

ACCESSORIES

Inlet Cone

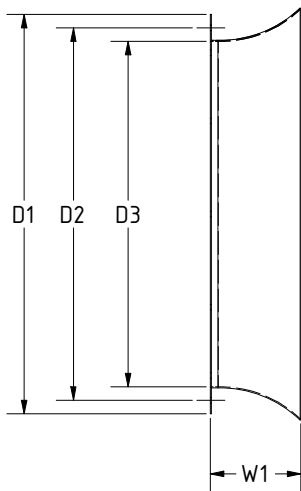

Matching Flange

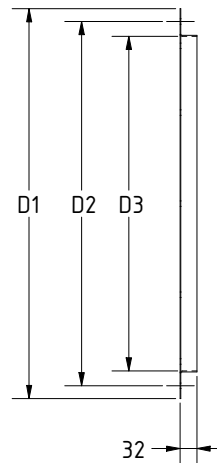

Flexible Connector

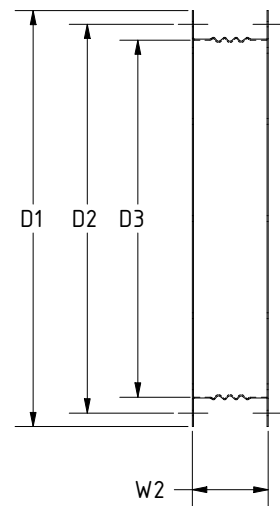

All dimensions are in mm

Model Size	D1 [MM]	D2 [mm]	D3 [mm]	W1 [mm]	W2 [mm]
355	440	405	360	166	132
400	486	448	402	166	132
450	536	497	451	166	132
500	586	551	505	166	132
560	666	629	566	166	132
630	736	698	635	166	132
710	816	775	712	171	132
800	906	861	798	251	132
900	1006	958	895	251	132
1000	1107	1067	1004	251	132
1120	1247	1200	1126	251	132
1250	1372	1337	1251	251	172
1400	1527	1475	1406	251	172
1600	1727	1675	1606	251	172

* Tubular Sound Attenuators for AXF Series Fans and other accessories are available on request.

SYSTEM EFFECTS

System Set-Up

Most of the time fans are field tested with open inlets which does not comply with type D. In this case, fan should have an integral inlet bell in order to simulate inlet ductwork. Figure 2 shows the streamlines the air follows as it enters a fan with a well-designed inlet bell and with a straight run of duct upstream of the fan. The airflow is smooth and the velocity at the entrance is uniform.

Figure 2. Air Streamlines at Fan Inlets

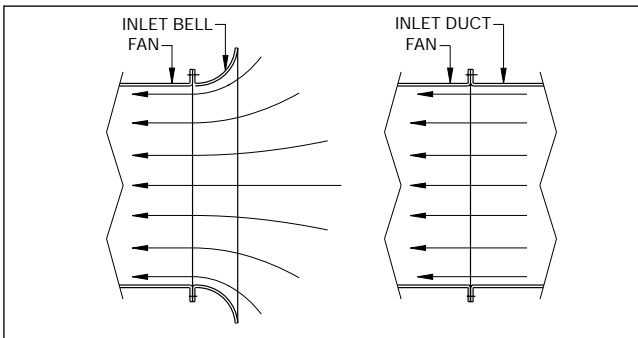

The velocity profile coming out of the most efficient fan is not laminar. In centrifugal fans, there are regions of high velocity air coming out of the impeller. Figure 3 shows typical outlet velocity profiles for centrifugal and axial fans.

Figure 3. Typical Outlet Velocity Profiles

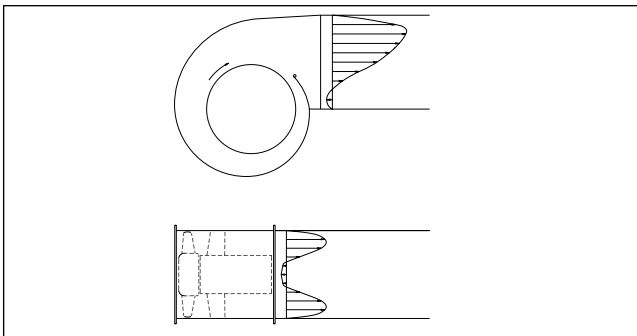

A length of straight duct is required at the outlet to allow the high velocity (kinetic energy) to be converted to static pressure (potential energy). To get full pressure conversion, a duct at least as long as the 100% effective duct length is required. AMCA defines the 100% effective duct length to be a minimum of two and one half equivalent duct diameters for outlet velocities up to 2,500 fpm, with 1 duct diameter added for each additional 1,000 fpm. Also it is important that the outlet connection to be smooth. In the test code, AMCA specifies that the area of the outlet duct be between 95% and 105% of the fan outlet area and that any transitions used have sides that are sloped not more than 15° on converging sections and 7° on diverging sections.

Duct fittings or fan installations that do not provide smooth uniform flow at the fan inlet or complete pressure recovery at the fan outlet cause the fan to perform at a level below its catalog rating. Elbows cause non-uniform airflow at fan outlet.

Inlet System Effects

Elbows mounted near the inlet of a fan are the most common inlet system effect. Elbows should be installed at least three equivalent duct diameters upstream of a fan inlet. Elbows which are mounted closer to the inlet of the fan can also cause pressure fluctuations, increased sound levels, and structural damage to the fan. As depicted in the previous example, elbows at a centrifugal fan's inlet cause a system effect. Often the elbow at the inlet is not a true elbow, but a drop box as illustrated in Figure 4

The system effect for this type of inlet elbow is nearly impossible to predict, as it is a function of fan type, inlet size, and box width and depth. Losses in flow rate as high as 45% have been observed with this type of inlet.

Figure 4. Inlet Elbow

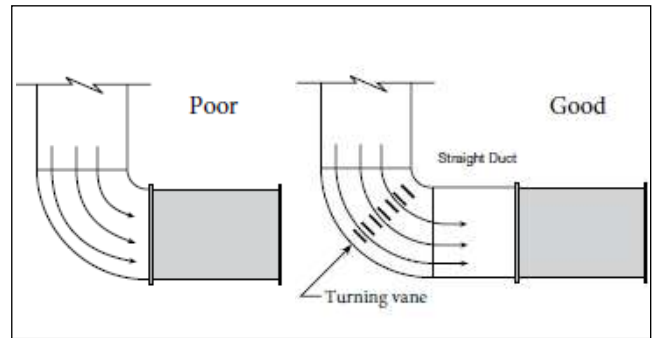

Outlet System Effects

The most common cause of system effects on fan outlets is an insufficient length of straight duct length that prevents the full conversion of velocity to static pressure. As defined previously, the length of straight duct length required is the 100% effective duct length. Many of the charts in AMCA Publication 201 use the blast area, which is the outlet area minus the area of the cut off.

Figure 5. Discharge Elbow

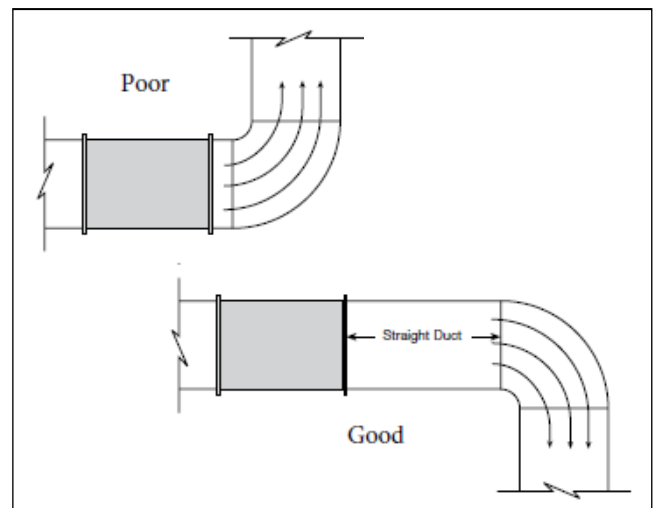

**THE RECOGNIZED LEADER IN
MANUFACTURING AND DISTRIBUTION
OF HVAC AND INDUSTRIAL
PRODUCTS IN THE MIDDLE EAST.**



MIDDLE EAST

PO Box 24021, Sharjah Industrial Area
United Arab Emirates
Phone: 971.6534.3488 | Fax: 971.6534.3710
energyintl.com

UNITED STATES

5959 Trenton Lane, Minneapolis, MN 55442
Phone: 763.551.7600 | Fax: 763.551.7601
careers.tcf.com